

Angle Bay Window & Bow Window Installation Instructions



IMPORTANT: Please read before you begin installation.

Table Of Contents And Tool / Material Requirements

	START PAGE
All Angle Bay/Bow Window Installation Instructions; Definition	iii
Safety Information	iv
Rough Opening Preparation	1
Weather Barrier Self-Adhering Tape, Utility Knife, Measuring Tape, Rubber Roller, Cloth Tape	
Sill Preparation – Straight Faced Wall	3
Measuring Tape, Utility Knife, Rubber Roller, High-Quality Exterior Neutral Cure Silicone Sealant, Caulking Gun	
Check Rough Opening for Level and Square	4
Measuring Tape, Level, Shims, Straightedge, High-Quality Exterior Neutral Cure Clear Silicone Sealant, Caulking Gun	
Supporting Wall Sill Preparation	5
Measuring Tape, Weather Barrier Self-Adhering Tape, Utility Knife, Rubber Roller, High-Quality Exterior Neutral Cure Clear Silicone Sealant, Caulking Gun	
Window Installation	6
Measuring Tape, Hammer, Fasteners (long enough to penetrate framing members by at least 1-1/2"), Pry Bar, Shims, Straightedge, Level, Sawhorse, Temporary Braces	
Square and Plumb the Interior	8
Level, Straightedge, Hammer, Shims	
Side Jamb Filler Piece Installation	9
2x4 Lumber, Saw, Electric Drill w/Drill and Screwdriver Bits, 2" to 3" Long Drywall Screws, 10D Casing Nails, Hammer, Measuring Tape	
Cable Support Kit Option Installation	10
Factory-Installed Cable Support Kit and Hardware Package, 1/2" Wrench, Flat-Bladed Screwdriver, Portable Jack, Level, Measuring Tape	
Wooden Support Bracket Option Installation	13
Measuring Tape, Level, Insulation, Hammer, Rust-Proof Wood Screws, Saw, 2x4 Lumber, Water-Proof Wood Glue, Electric Drill w/Drill and Screwdriver Bits, Wooden Support Brackets	
Weather Barrier Self-Adhering Tape Application	14
Weather Barrier Self-Adhering Tape, Utility Knife, Measuring Tape, Rubber Roller	
Recommended Finishing Instructions	15

All Angle Bay/Bow Window Installation Instructions

⚠ IMPORTANT: Thoroughly read and follow these instructions. Failure to install as recommended will void any warranty, expressed or implied. **Before installation, check building codes for the area in which the windows are being installed to ensure proper compliance.** The installation instructions that follow are based on typical frame construction. Specific applications may differ. The window manufacturer recommends that you consult a qualified installation professional. The window manufacturer is not responsible for installation.

⚠ IMPORTANT: A number of jurisdictions have adopted building code design pressure requirements that require window and door products be installed in the same way they were installed for laboratory testing. Check your local building codes to see if these requirements apply to your installation.

Sealant **must** be applied in all installations. Follow guidelines below and details contained in the following installation instructions for non-rated installation.

- A 3/8" sealant bead must be applied to the rough opening (or the back of the nailing fin) so that the sealant aligns with the nailing fin pre-punched holes. Do not caulk the sill nailing fin.
- The nailing fin or exterior casing must contact the sealant continuously along the head and sides of the unit and must fully contact the exterior face of the wall around the unit's entire perimeter.
- A shim space is required around all sides of the window to allow for structure movement, seasonal expansion and contraction, and to provide space for insulation. The rough opening must provide a shim space that does **not exceed:**
3/8" on all sides (3/4" total for either width or height) for vinyl units with a nailing fin;
OR
1/2" wider on the sides (1" total for width) and 1/4" on top or bottom (1/2" total for height) for clad or wood brickmould windows.

NOTE: Shim space for maintaining DPR ratings cannot exceed 1/4" on all sides (RO total of 1/2" larger than frame width or frame height).

If a shim space greater than listed above exists on the interior or exterior of the unit, use solid continuous furring material to fill this space until the maximum shim allowance is achieved.

Accessories, such as jamb extension, may alter unit width and height. Check rough opening size vs unit size accordingly.

- Furring material must be solid, continuous, and run the full height and/or width of the rough opening. Furring strip depth must be at least equal to window jamb depth.

ADDITIONAL NOTES FOR ALL INSTALLATIONS:

- For any installation that has exposed fasteners, it is recommended to use fasteners made of 300 series stainless steel. Follow your local codes if they specify a different series of stainless steel.
- Certain options, accessories, and warranty considerations require the unit be installed using installation clips. Contact your customer service representative for additional assistance.

Definition: 

Weather Resistant Barrier (WRB) is a material used to provide moisture control. Usually applied over sheathing and underneath siding; often called "house wrap".

Window manufacturer reserves the right, as necessary, to change product specifications, installation procedures, materials, prices and terms of purchase without notice.

Safety Information



Recognize this symbol. This is the Safety-Alert symbol. When you see this symbol be alert to the potential for personal injury or product damage.



DANGER

Falling from window opening may result in serious injury or death. DO NOT leave openings unattended when children are present.



DANGER



CUT HAZARD

*Non-safety Glass.
*May cause serious injuries if broken.
*Do not install where tempered safety glass is required.



WARNING

Weight of window and door unit(s) and accessories will vary. Use a reasonable number of people with sufficient strength to lift, carry and install window or door unit(s) and accessories. Always consider site conditions and use appropriate techniques when installing.



DANGER



Screen will not stop children, any one or anything from falling out window.

Keep children and objects away from open window.



WARNING

Improper use of hand and power tools could result in personal injury and/or product damage. Follow equipment manufacturers' instructions for safe operation. Always wear safety glasses.



IMPORTANT: High-quality, exterior, neutral-cure, clear, silicone sealant (compatible with all window and door materials and the exterior face of the wall) is to be used for all procedures in the following instructions which call for caulking or sealant.



CAUTION Do not nail or screw through factory-applied finish. Breaking exterior finish coating voids warranty. (Does not apply to factory-applied primer paint.) To prevent penetrating factory-applied finishes, install with interior installation clips. Obtain clip installation instructions, part #1037024.

Rough Opening Preparation

FIGURE 1

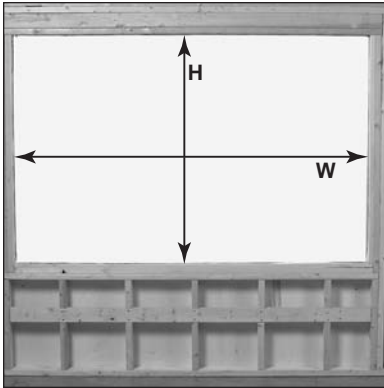

FIGURE 2

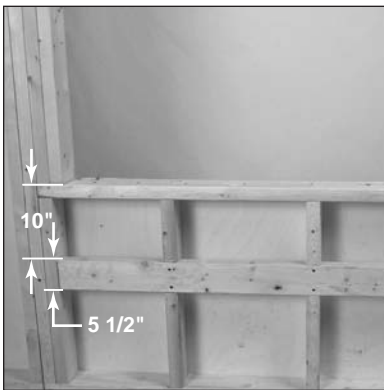
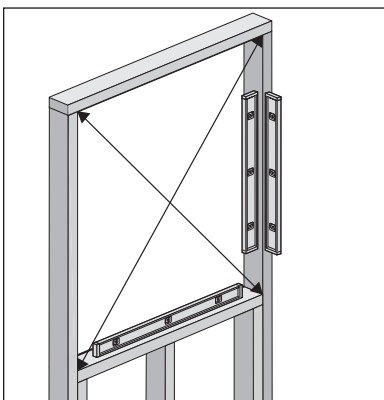

FIGURE 3



⚠ IMPORTANT: BEFORE starting make sure you have:

- The correct window type (casement, tilt, etc.)
- The correct size window (Width and Height) for your rough opening (FIGURE 1).
- Accessories, such as jamb extension, may alter unit width and height. Check rough opening size vs unit size accordingly.
- If using a sill pan, be sure rough opening size will accommodate both the window unit and the sill pan.
- Perform a complete unit inspection checking for shipping damage, broken glass, or other physical damage. Fix whatever is wrong before installation or start appropriate claim procedures.
- When accessories such as jamb extension have been ordered, apply according to the directions BEFORE you install the unit OR prep the rough opening.

The rough opening must provide a shim space that **does not exceed:**

3/8" on all sides (3/4" total for either width or height) for vinyl windows with a nailing fin. OR

1/2" wider on the sides (1" total for width) and 1/4" on the top or bottom (1/2" total for height) for clad or wood brickmould windows.

If a shim space greater than listed above exists on the interior or exterior of the unit, use solid continuous furring material to fill this space until the maximum shim allowance is achieved.

Furring material must be solid, continuous, and run the full height and/or width of the rough opening. Furring material depth must be at least equal to window jamb depth. Furring material must be securely fastened to the rough opening framing.

1. Measure the rough opening to ensure it meets the guidelines listed above. Check the rough opening dimensions against the unit's actual frame height and frame width.

2. When an optional wooden Bow/Bay Support Bracket is used, cut in a 2x6 stud placed on edge, 10" down from the top of the sill plate (FIGURE 2). Cut this framing piece into the outer edges of the interior framing members.

3. Make sure walls are plumb and not twisted. Check rough opening for square by measuring diagonally from corner to corner in both directions. Diagonal measurements cannot differ from each other by more than 1/4" (FIGURE 3).

⚠ IMPORTANT: Fix problems with plumb, level or square before proceeding.

Rough Opening Preparation (cont.)

FIGURE 4

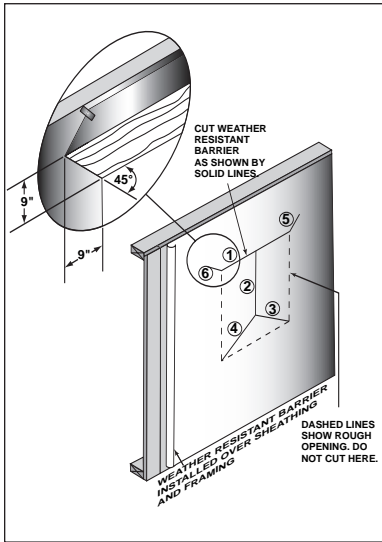

The following instructions are for structures with weather resistant barrier (WRB) applied before the windows are installed.

WARNING

Improper use of hand and power tools could result in personal injury and/or product damage. Follow equipment manufacturers' instructions for safe operation. Always wear safety glasses.

4. Cut weather resistant barrier (WRB) in sequence as shown by the circled numerals in (FIGURE 4).
5. Fold sill and side jamb WRB into the rough opening (FIGURE 5). Lift head WRB up and tape to face of wall (FIGURE 5).
6. Secure WRB to interior framing with staples placed every 12" to 16" apart (FIGURE 6).

FIGURE 5

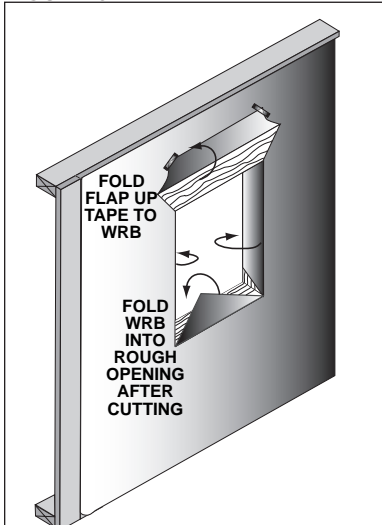
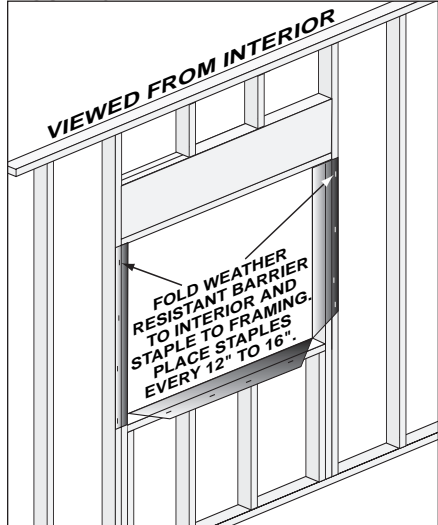

FIGURE 6



Sill Preparation – Straight Faced Wall

FIGURE 1

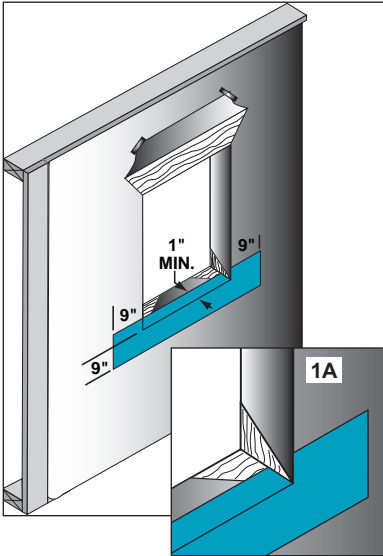
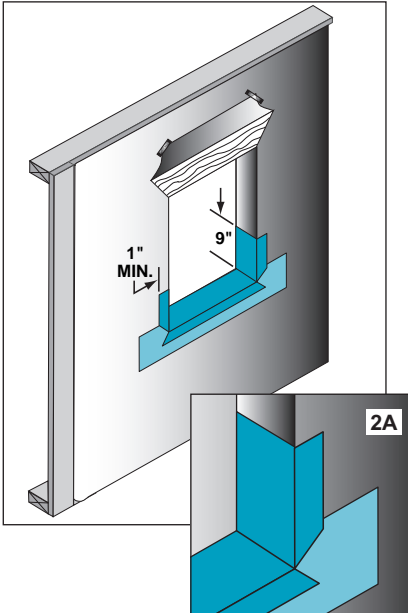

FIGURE 2



NOTE: Some tape manufacturer's recommend a primer be applied before using their tape on top of bare wood. Check and follow the tape manufacturer's instructions.

See Page 5 when a shaped supporting wall is used for sill support.

1. Cut a piece of weather barrier self-adhering tape 9" tall and as long as the opening width plus 18". Apply to face of exterior wall so 1" extends above the opening and 9" extends beyond each side of the opening (FIGURE 1). Cut along the corners of rough opening and fold down onto the sill (FIGURE 1A). Use a rubber roller to apply.
2. Apply a second continuous piece of weather barrier self-adhering tape on the top surface of the rough opening sill (FIGURE 2).
3. Cut the second piece of weather barrier tape the thickness of the wall plus 1". Make the tape 18" longer than the width of the opening.
4. Align flush with interior of the wall and extend edge of the tape at least 1" past the exterior wall surface (FIGURE 2). Start the piece 9" up the side of the rough opening and run it to the bottom of the opening, to the other side of the opening, and 9" up the other side (FIGURE 2).
5. Use a utility knife to cut the sill piece on both corners of the rough opening, and fold along the outside wall (FIGURE 2A).

⚠ IMPORTANT: High-quality, exterior, neutral-cure, clear silicone sealant (compatible with wood, vinyl, aluminum, fiberglass and the exterior face of the wall) is to be used for all the procedures in the following instructions which call for caulking or sealant.

⚠ IMPORTANT: Check both the weather barrier self-adhering tape and weather resistant barrier manufacturer's instructions to ensure the sealant you use is compatible with their product.

Check Rough Opening for Level and Square

FIGURE 1

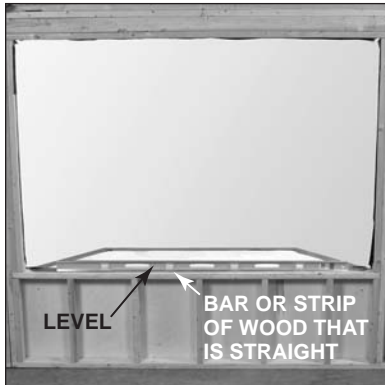

1. Check the rough opening sill for level (**FIGURE 1**). If sill plate is not level or straight place a 1-1/2" x 4-1/2" shim under the low side. Adjust shim until level is achieved.

NOTE: If level isn't long enough to reach across entire sill use a straightedge with the level.

⚠ IMPORTANT: To ensure that the sash operate smoothly, make sure that the sill is level and straight.

2. Measure the opening diagonally from corner-to-corner (**FIGURE 2**). The measurements should not differ more than 1/4". Fix problems before continuing.

Apply a continuous 3/8" bead of silicone sealant around the sides and head of the rough opening perimeter. Locate sealant so it does not intrude into the opening, aligns with the pre-punched nailing fin holes, and will also provide a continuous seal between the face of the wall and the nailing fin or exterior casing trim (**FIGURE 3**).

Caulk around the head and sides of the rough opening. **Do not caulk the sill.**

When the window is installed the caulk bead must contact the nailing fin or exterior casing continuously so it seals the nailing fin and/or exterior casing against the face of the wall.

FIGURE 2

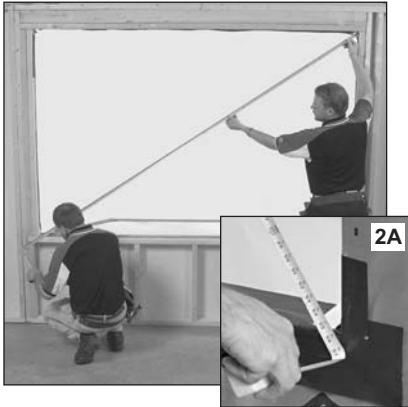
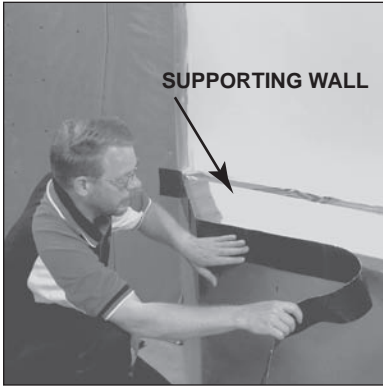

FIGURE 3



Supporting Wall Sill Preparation

FIGURE 1



An angle bay/bow window can be installed using either a supporting wall (shown left) or with the aid of manufacturer options which include a Cable Support Kit and Wooden Support Brackets.

1. Cut a piece of weather barrier self-adhering tape 10" wide and as long as the opening width plus 18". Apply to face of supporting wall (**FIGURE 1**) so 1" extends above the opening and 9" extends beyond each side of the opening (**FIGURE 2**).

FIGURE 2

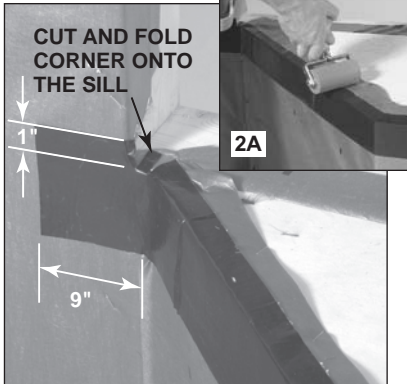

2. Cut along the corners of rough opening and fold down onto the sill (**FIGURE 2**). Use a rubber roller to apply (**FIGURE 2A**).

FIGURE 3



3. Apply a continuous 1/2" bead of caulk to the exterior face of the supporting wall, located 1/4" from the rough opening edge (**FIGURE 3**). Caulk around the sill and both sides of the rough opening.

When the window is installed the caulk bead must contact the nailing fin or casing trim continuously so it seals them against the face of the wall.

Window Installation

FIGURE 1



⚠ IMPORTANT: Make sure sash are closed and locked. Remove all shipping and packing material.

1. From the exterior, carefully lift and center window into rough opening (FIGURE 1).

⚠ WARNING

Temporary support must be sturdy enough to carry weight of entire window unit. Support must also be stable enough so it will not collapse while window unit is repositioned during installation.

If a bottom structure or support wall is not present, use temporary braces or a saw horse under the outer edge of the projection to stabilize the unit. Temporary support (FIGURE 2) must hold the unit in a plumb position until window is fully secured.

2. Secure one side top corner with a fastener long enough to penetrate the framing material by at least 1-1/2" (FIGURE 3).
3. Recheck the unit for level. Adjust if needed. Nail or screw in other top corner.

FIGURE 2



FIGURE 3



Window Installation (cont.)

FIGURE 4



4. From inside, check again for level, plumb and square. Slide bottom of window left or right until diagonal measurements are exactly the same (FIGURES 4A – 4D). Fasten bottom corners.

5. Check again for level, plumb and square. Use shims and a straightedge to straighten the side and top jamb. When straight, fasten through the pre-punched holes in the nailing fin. In a similar manner, straighten the sill and fasten through all of the pre-punched holes in the sill nailing fin. Finish securing unit in opening by nailing or screwing through all the prepunched holes in the nailing fin. Fastener heads should not over compress the nailing fin.



Square and Plumb the Interior

FIGURE 1

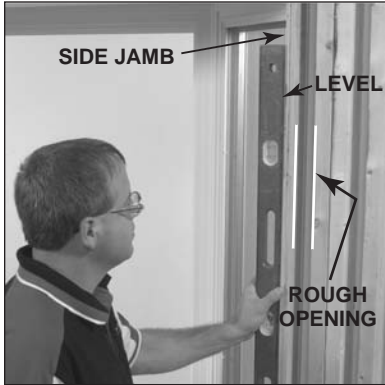

1. Place a level on the inside of the side jamb (**FIGURE 1**), check for straightness.

If side jamb isn't plumb, place a shim between the side jamb and the rough opening (**FIGURE 1**). Adjust shim until side jamb is straight.

2. Repeat Step 1 for other side jamb (**FIGURE 2**).

3. Check sill for level. Place shims between the bottom of the seat board and the rough opening to make level (**FIGURE 3 & 3A**).

⚠ IMPORTANT: Do not over pack insulation.

Loosely insulate between the window frame and rough opening with fiberglass.

OR

You can use minimal expansion foam products specifically designated and certified as meeting ASTM and AAMA requirements for "door or window use" to fill the shim space between the window frame and the rough opening. Foam manufacturer's installation and curing instructions must be followed.

FIGURE 2



FIGURE 3

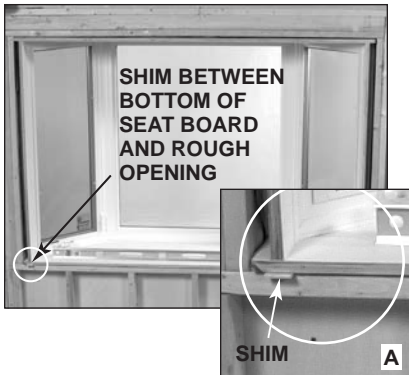

Side Jamb Filler Piece Installation

FIGURE 1



1. There will be an installation opening between the side jambs and the rough opening. Cut a 2x4 stud the width and length of the space, one for each side (FIGURE 1).

FIGURE 2



2. Place the filler piece in the installation opening, and nail or screw, at a slight angle, into the rough opening and into the unit side jamb (FIGURE 2).

FIGURE 3



Cable Support Kit Option Installation

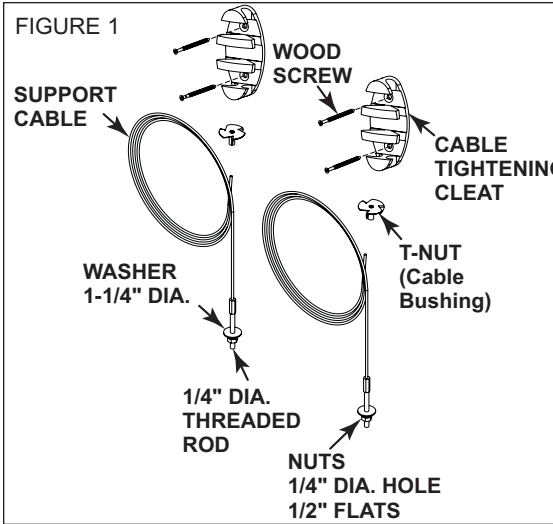

Recommended for Suspended Installations

Before you begin, make sure all sash are closed and locked.

Kit Includes:

- 2 - Cable Tightening Cleats (FIGURE 1)
- 4 - 1-1/2" Wood Screws (FIGURE 1)

Pre-Installed on Unit:

- 2 - Support Cables (Top of unit) (FIGURES 1 & 2)
- 2 - T-Nuts (Cable Bushing) (FIGURES 1 & 2)
- 2 - Washers (Bottom of unit) (FIGURES 1 & 3)
- 4 - Nuts (Bottom of unit FIGURES 1 & 3)

FIGURE 2

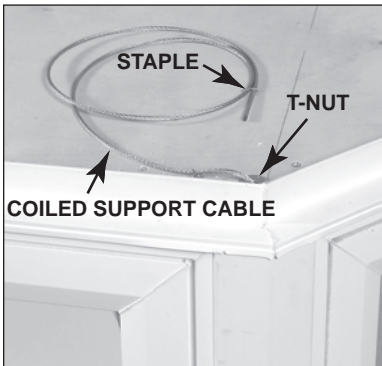
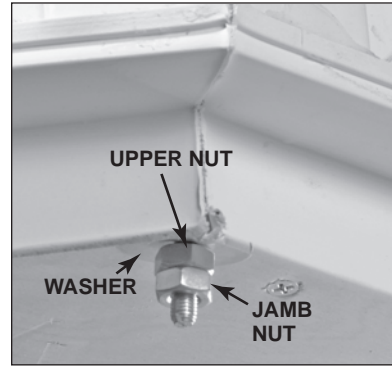

FIGURE 3



Cable Support Kit Option Installation (cont.)

FIGURE 4

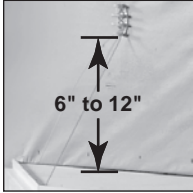

FIGURE 5

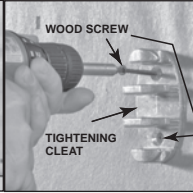

FIGURE 6

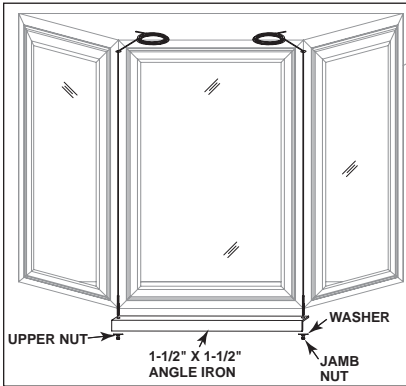
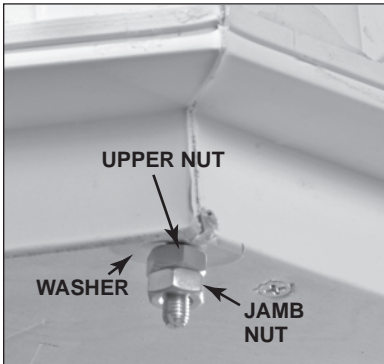

FIGURE 7



1. Use temporary support (**FIGURE 2, PAGE 6**) while cable system is being installed. Support unit slightly above level.

WARNING

Do not anchor cleats to rafter tails. Cleats must be attached solidly into side grain of framing members. End grain, such as rafter tails, do not provide adequate holding strength.

2. Position cable tightening cleats directly above T-nuts when adequate anchoring is possible (**FIGURE 4**).

3. Attach tightening cleats (**FIGURE 5**) to structure's top plate or header with wood screws, about 6"-12" above the unit (**FIGURE 5**). Make sure cleat location will not interfere with any further framing.

NOTE: Extra support can be added to any size unit. Measure, cut and drill a 1-1/2" angle iron as in (**FIGURE 6**). Remove jamb nut, upper nut and washer. Slide angle iron over threaded studs and secure with washer, upper nut and jamb nut.

CAUTION

Cable is free to pull down through unit after being unstapled and uncoiled. Take care that cable does not slip out.

4. Unstaple the coiled cable from the top of the unit. T-Nut in head board acts as a bushing for the cable and remains as part of the installation.

5. From the top of the unit pull cable tight so that washer on the bottom of the cable is in contact with the bottom of the unit (**FIGURE 7**).

Cable Support Kit Option Installation (cont.)

FIGURE 8

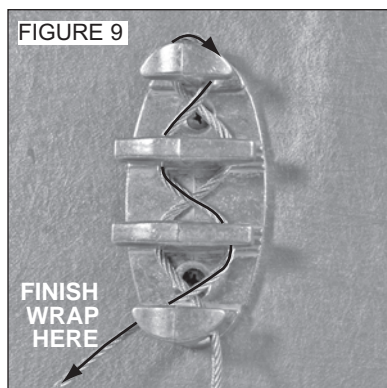
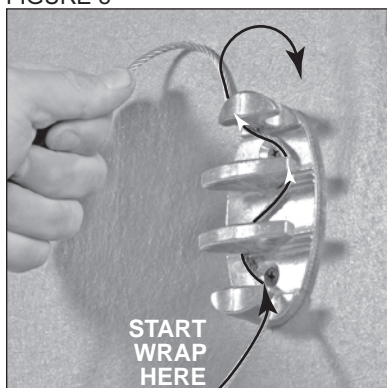
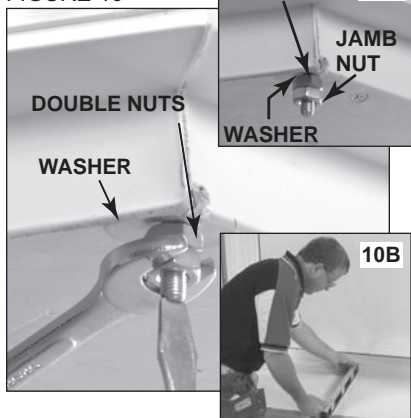

FIGURE 10



Secure cable to tightening cleat.

6. Before starting to wrap onto cleat, pull cable as tight as possible by hand. Start wrapping at bottom right hand side of the cleat. Wrap in a zig-zag fashion around the cleat as shown in (FIGURE 8). Complete the wrap by running the cable over the top of the cleat and zig-zagging the opposite way (FIGURE 9). Repeat procedure to secure and tighten second cable.

NOTE: The cable system's threaded bottom end, jamb nut, upper nut, and washer provide a way to achieve final level.

7. Adjust upper nut and jamb nut on bottom of unit so that cables are taught (FIGURES 7 & 7A).

8. Remove temporary support so cable system carries unit's weight.

9. Check unit for level, plumb, sash reveal and operation (FIGURE 10B).

To make adjustments:

NOTE: A small jack such as a Port-A-Power should be used to adjust window up or down to achieve level. Do not use upper nut to raise or lower entire window unit.

10. Reinstall temporary support.

11. Loosen Jamb Nut with a 1/2" wrench by turning nut COUNTER-CLOCKWISE.

12. Adjust jack up or down as required by checks made in step 10. Check unit again for level, plumb, sash reveal and operation.

13. Using a 1/2" wrench turn Upper Nut. Turning CLOCKWISE RAISES the unit. Turning nut COUNTER-CLOCKWISE LOWERS the unit.

14. Placing a standard screwdriver in the slot at the cable end will keep cable from twisting while nuts are being adjusted (FIGURE 10).

15. When level, plumb, even sash reveal and smooth sash operation are achieved, hold Upper Nut with a wrench to prevent movement, then with a second wrench securely tighten the Jamb Nut (FIGURE 10A).

16. Remove portable jack and temporary support from beneath unit.

Wooden Support Bracket Option Installation

FIGURE 1

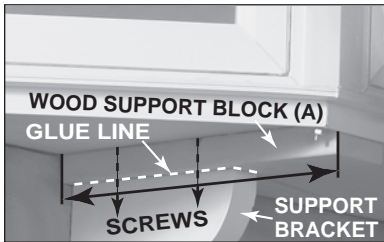

NOTE: Support Brackets can be ordered from the window manufacturer.

Support Brackets are installed in pairs

1. Before installing the support bracket, check sill for level. If adjustments are required see (PAGE 12, STEPS 11 THROUGH 17).

CAUTION

Wooden support brackets must be anchored to the seat board and to the structure's framing (FIGURE 2, PAGE 1).

FIGURE 2

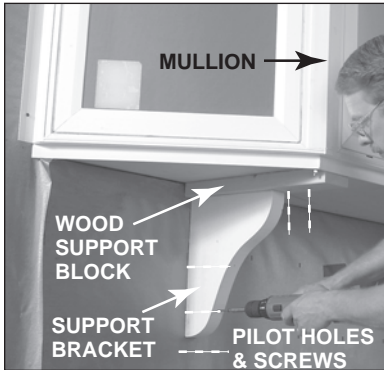

2. From a 2x4 cut two wood Support Blocks to length (FIGURE 1 Item A).

3. Attach a Support Block to a Support Bracket. Use waterproof wood glue and rust-proof wood screws. Prevent wood splitting by drilling pilot holes for the screws.

4. Drill pilot holes vertically and horizontally through the Wood Support Block and Support Bracket (FIGURE 2).

5. Attach the Wood Support Block and Support Bracket Assembly to the structure framing members and seat board with rust-proof wood screws.

6. Assemble and attach matching support in a similar manner.

7. Insulate and finish bottom of unit.

FIGURE 4



Weather Barrier Self-Adhering Tape Application

FIGURE 1



1. On the exterior, apply a high-quality weather barrier self-adhering tape. Apply to the sides, starting at the top of the head nailing fin and run it down so that it extends 6" past the bottom nailing fin. Tape must cover the entire nailing fin, including the installation holes and the joint between the fin and the building's sheathing. Use a rubber roller to apply (**FIGURES 1 & 2**).

(**FIGURE 3**) Shows cable support system, this can be ordered separately for your installation.

FIGURE 2



Shown with supporting wall. Does not show optional cable support system or support brackets.

FIGURE 3



Shown with optional cable support system and wooden support brackets.

Recommended Finishing Instructions



WARNING

Always follow chemical manufacturers' safety instructions when using chemicals to avoid injury or illness.

Vinyl, aluminum, and fiberglass may be cleaned with mild soap and water. Hard to remove stains and mineral deposits may be removed with mineral spirits. Factory-applied painted surfaces can be cleaned with mild household detergents and water.

- Do **NOT** clean any surface with gasoline, diesel fuel, solvent based, or petroleum based products.
- Do **NOT** use abrasive materials or strong acidic solutions against vinyl, aluminum, glass, or factory-applied finishes.
- Do **NOT** scrape or use tools that might damage the surface.
- Do **NOT** paint vinyl or aluminum surfaces.
- Do **NOT** use mastic-type tapes such as Duct Tape[®].

NOTE: If masking tape is used on any surface to aid in painting or staining, remove tape as soon as possible after use. Tape must be removed within 24 hours of application.

For long term use, such as stucco applications; use tape that will release, even when exposed to high temperatures for an extended period of time. (Examples include 3M #2080 and #2090 tapes.)

For Bare Wood Surfaces

For best results, we recommend sealing your wood products immediately upon receipt. Avoid storing products or leaving them unfinished for more than 30 days.

1. Remove all construction and adhesive label residue with mineral spirits before finishing.
2. Lightly sand surfaces being finished with 180 grit or finer sandpaper. Be careful not to scratch the glass.
3. After sanding, clean-off sanding dust using lacquer thinner applied to a cloth so the cloth is slightly damp. Let surface dry completely.

-If a painted surface is desired:

- If a wood unit is delivered with factory-applied primer paint, it may be painted without repriming, providing the finish paint coat is applied within six (6) months of unit installation.

- If a factory-primed wood unit requires repriming contact your customer service representative for help in selecting a primer compatible with the factory applied material.
- Factory-applied AccentialsTM color system finishes in standard, designer or custom colors do not require additional painting. For "touch up" paint specifications contact your customer service representative.

1. An unprimed wood unit requires priming. Use high quality acrylic or oil-based primer. Use compatible oil or high quality acrylic finish coats. Refer to the primer and paint manufacturers' instructions.
2. When priming bare wood or repriming, cover all exposed wood surfaces. Priming all exposed surfaces helps prevent end splitting, warping and/or checking.
3. Once primed, apply two (2) coats of paint on all exposed wood surfaces.

-If a stained surface is desired:

 **CAUTION** If no sealer is applied over stain, the wood will weather very rapidly and defects will occur. Apply at least two (2) coats of sealer.

1. Use only oil-based stain. A gel stain is easier to apply as it does not easily run or drip. The clear top coats may be oil or water-based. Apply at least two top coats of sealer or varnish.
- Stain applied to soft and porous woods such as pine, maple, alder, and fir can result in splotchy or uneven color appearance. Softer areas absorb pigmented stain more readily than harder areas, making the soft spots darker. The uneven absorption is especially prevalent with heavily pigmented darker stains. To determine if your stain choice is heavily pigmented and prone to splotchy application, view the opened and stirred stain container with an indirect light source. If you can see "down into" the stain, it is a lighter pigmented variety. If you cannot see "down into" the stain, it is a heavily pigmented type and will be prone to uneven absorption.

Continued on the next page.

Recommended Finishing Instructions (cont.)

- A pre-stain wood conditioner, applied before staining, will help softer woods absorb stain more evenly. Apply both wood conditioner and desired stain according to the manufacturers' instructions.
- 2. Apply one (1) coat of sealer to the stained surface and let dry. Use a high-quality, exterior grade, uv-stabilized, clear polyurethane varnish. Let sealer dry completely.
- 3. Before applying the next finish coat, make sure the previous coat is completely dry. Then lightly sand previous finish coat with 180 grit or finer sandpaper. Clean off all sanding dust and wipe surfaces with a tack cloth.
- 4. Apply next coat of desired finish to surface and let dry. Apply only one coat at a time.
- 5. For any additional coats of finish, repeat steps 3 and 4.

-For a clear (natural) finish: Follow Steps 1, 2, and 3 under "Bare Wood" and Steps 2, 3, 4, and 5 under "stained surface".

⚠ IMPORTANT: Remove sash for finishing. Apply your choice of sealer (paint or varnish) to all exposed wood components. Do not get sealer on weather strip or into mechanical components (sash lock, tilt latches, operators, or sash rollers). Ensure bottom and top of sash are also sealed (FIGURE 1).

⚠ CAUTION Sealer (paint or varnish) applied to sash **MUST DRY COMPLETELY** before reinstalling sash. If not dry, sash may stick in jamb liners. Also weatherstrip and jamb liners may be damaged.

PVC Trim

- Painting or finishing PVC trim is not required.
- If desired, PVC trim can be painted with high-quality exterior latex or oil base paint.
- PVC trim can be cleaned with most major household cleaners. Glass cleaners work the best.
- Cleaners to Avoid
 - Harsh cleaners with glycol ethers or ethanol type solvent and/or isopropyl alcohol soften the coating if left on for several minutes. Cleaners such as Goof Off, Wal-Mart "Great Value All-Purpose Cleaner" (glycol ether), 409 General Purpose (2-Butoxyethanol) and Greased Lightning (glycol ether), citrus cleaners, abrasive cleaners, and solvents such as acetone, paint remover, and lacquer thinner are NOT recommended for cleaning PVC trim.
- Touch up can be performed with:
 - Royal Fillers – touch up markers and aerosol sprays
 - Dap "All Purpose" Painters Putty
 - Minwax Hi Finish Light Wood Filler
 - Sherwin Williams Shrink Free Spackling

⚠ CAUTION Solvent based fillers should not be used.

FIGURE 1 Sash Bottom

