

**1-Wide, 2-Wide, 3-Wide and 4-Wide
Sliding Patio Door &
French Sliding Patio Door
Installation Instructions
For Clad Nailing Fin & Wood Brickmould Units**

[Includes Instructions to Maintain Design Pressure 50 Test Ratings]



IMPORTANT: Please read before you begin installation.

NOTE: A gray background is applied to pages where the installation instructions apply exclusively to units with wood brickmould.

Definition: 

Throughout these instructions DPR equals “For Design Pressure Rating”. Any procedure so titled **must be** completed to maintain the rating validity. **Non-DPR** is for installations not requiring maintenance of design pressure ratings. In this case you can follow procedures for either DPR or non-DPR.

Information in this booklet is divided into the following sections.

- **GENERAL – ALL INSTALLATIONS** – Applies to all door types. Starts on Page 1.
- **INSTALL – CLAD NAILING FIN UNITS** – How to install these units. Starts on Page 6.
- **INSTALL – WOOD BRICKMOULD UNITS** – How to install these units. Starts on Page 11.
- **ALL INSTALLATIONS** – Handling information for screens, inserts etc. Starts on Page 16.
- **4-WIDE DOOR** – Frame assembly instructions. Starts on Page 24.

Thumb indexes on the page edge show the start of each section. Specific topics can be located by checking the bold entries in the “Table of Contents and Tool / Material Requirements”.

Table Of Contents And Tool / Material Requirements

	PAGE
Definition DPR and non-DPR	ii
General Installation and DPR Attainment	iv
Design Pressure Performance – Fastening Method (chart)	v
Design Pressure Performance – Nailing Fin Configuration	v
Door Operation	vi
Safety Alert Symbol; A Special Note About Masonry	vii
GENERAL – ALL INSTALLATIONS	
Check Rough Opening Size (For DPR and Non-DPR)	1
Measuring Tape & Level	
Check Rough Opening for Level and Square;	
Straighten and Level Subfloor (For DPR and Non-DPR)	2
Level, Hammer, Nails, Nail Set, Plane	
Sill and Rough Opening Preparation (For DPR and Non-DPR)	3
Weather Barrier Self-Adhering Tape, Utility Knife, Measuring Tape, Rubber Roller, Silicone Sealant, Caulking Gun	
Housewrap & Caulking Rough Opening Details For Preserving Design Pressure Ratings On Structure With Housewrap	5
Measuring Tape, Clear Silicone Sealant, Caulking Gun, Utility Knife, Cloth Tape	
INSTALL – CLAD NAILING FIN UNITS	
Door Installation For Clad Nailing Fin Units (For DPR and Non-DPR)	6
Measuring Tape, Hammer, #8 Steel Screws (long enough to penetrate framing material at least 1-1/2”), Electric Drill w/Screwdriver Bit, Pry Bar, Shims, Straightedge, Level	

Gen - All

Table Of Contents And Tool / Material Requirements

	PAGE
<u>INSTALL – CLAD NAILING FIN UNITS</u> (continued)	
Housewrap & Caulking Finishing Details For Preserving Design Pressure Ratings On Structure With Housewrap	8
Utility Knife, Scissors, Cloth Tape, Silicone Sealant, Caulking Gun	
Weather Barrier Self-Adhering Tape Application – Units With Nailing Fin	9
Weather Barrier Self-Adhering Tape, Utility Knife, Measuring Tape, Rubber Roller, Weather Barrier Sealing Tape	
<u>INSTALL – WOOD BRICKMOULD UNITS</u>	
Door Installation For Wood Brickmould Units (For DPR and Non-DPR)	11
Measuring Tape, Hammer, #8 Stainless Steel Screws (long enough to penetrate framing material by at least 1-1/2"), Electric Drill w/Screwdriver Bit, Pry Bar, Shims, Straightedge, Level	
Drip Cap Installation – Wood Brickmould Units	13
Measuring Tape, Hacksaw, Roofing Nails (long enough to penetrate framing material at least 1-1/2"), Hammer, Silicone Sealant, Caulking Gun, Drip Cap	
Weather Barrier Self-Adhering Tape Application – Units With Wood Brickmould	14
Weather Barrier Self-Adhering Tape, Utility Knife, Measuring Tape, Rubber Roller	
Housewrap & Caulking Finishing Details For Preserving Design Pressure Ratings On Structure With Housewrap	15
Utility Knife, Scissors, Cloth Tape, Silicone Sealant, Caulking Gun	
<u>ALL INSTALLATIONS</u>	
Square and Straighten the Interior – All Installations	16
Measuring Tape, Shims, Level, Fiberglass Insulation, Hammer, Pry Bar	
Removing Screen; Installing Screen – All Installations	17
Phillips Head Screwdriver	
Screen Adjustment; Installing Screen Keeper – All Installations	18
Measuring Tape, Pencil, Phillips Head Screwdriver	
Remove & Install Active Insert; Adjust Active Insert – All Installations	19
Phillips Head Screwdriver	
Install Handles and Lock – All Installations	20
Phillips Head Screwdriver, Measuring Tape, #2 Pencil or Carpenter Pencil	
Recommended Finishing Instructions – All Installations	22
<u>4-WIDE DOOR</u>	
4-Wide Door Frame – General	24
Electric Drill w/Drill and Screwdriver Bits, Wood Glue, Exterior Wood Filler, Assembly Hardware Package With Screws and Corner Keys, Silicone Sealant, Caulking Gun, Q-LON Corner Seal, Shop Towels, Denatured Alcohol, Framing Square, Measuring Tape	
Assemble 4-Wide Door Frame – Clad Nailing Fin and Wood Brickmould Units	25
4-Wide – Inactive Insert Installation	29
{Same tools and supplies as 4-Wide – General}	
Stucco Products	36

General Installation and DPR Attainment

⚠ IMPORTANT: Thoroughly read and follow these instructions, failure to install as recommended will void any warranty, expressed or implied. **Check building codes for the area in which the doors are being installed before installation to ensure proper compliance.** The installation instructions that follow are based on typical frame construction. Specific applications may differ. The door manufacturer recommends that you consult a qualified installation professional. The door manufacturer is not responsible for installation.

⚠ IMPORTANT: A number of jurisdictions have adopted building code design pressure requirements that require door products be installed in the same way they were installed for laboratory testing. To comply with these requirements, we are pleased to supplement the installation instructions with the following:

Sealant **must** be applied in all installations. There must be continuous contact with a generous bead of sealant between **bare** sheathing and the door unit's brick mould or nailing fin around the door's perimeter.

The following additional steps must be taken as appropriate.

- Exterior house wrap must be cut and temporarily taped back away from rough openings.
- When sealant is applied to the rough opening it must be applied directly to the building's sheathing and **NOT** the building wrap.
- The nailing fin or brick mould must contact the sealant continuously along the entire perimeter of the unit and must fully contact exterior face of the wall around the door's entire perimeter.
- Exterior housewrap must be trimmed and reapplied over the nailing fin. It must be sealed to the fin along the entire perimeter with silicone sealant.
- For brick mould units, housewrap must be trimmed and reapplied so it butts tightly to the brick mould. Cut edges of housewrap must be sealed around the entire perimeter of the door.

Refer to the chart on Page v to select a fastening method that meets test specifications.

INSTALL NOTES:

A shim space, not to exceed 1/4", is required. If a shim space greater than 1/4" exists on the interior or exterior of the unit, use solid material to fill this space until the maximum 1/4" shim allowance is achieved. **Doors do not require a 1/4" shim space at the sill.**

ADDITIONAL NOTES:

- For brick mould units, or any installation that has exposed fasteners, it is recommended to use fasteners made of 300 series stainless steel. Follow your local codes if they specify a different series of stainless steel.
- Certain options, accessories and warranty considerations require the unit be installed using installation clips. The clip install method has not been tested for design pressure ratings and should not be used where design pressure ratings must be maintained. Contact your customer service representative for assistance.

Design Pressure Performance – Fastening Method

Aluminum Clad Wood Patio Door With Pre-Punched Fastener Holes Or Wood Door With Wood Brick Mould		
Unit Description	Fastener	How to Fasten
<p>Nailing Fin with Pre-Punched Fastener Holes / No Brick Mould See FIGURE 1 below. See Important Note below.</p>	<p>#8 Steel screws long enough to penetrate framing material by at least 1-1/2".</p>	<p>Start a screw 4" in from corner and apply through nailing fin into framing member. Space additional screws every 4" on center, around entire perimeter, staying 4" from each corner.</p>
<p>Wood Brick Mould – See FIGURE 2 below. See Important Note below.</p>	<p>#8 Steel screws long enough to penetrate framing material by at least 1-1/2"</p> <p>Drill a 3/32" pilot hole in brick mould. Start 4" from corner and space holes 12" on center around entire perimeter, staying at least 4" from each corner. <i>For a neater appearance, countersink pilot holes, sized to screw heads.</i></p>	<p>Apply screws through each pilot hole and tighten firmly. Screws must be no more than 12" on center from each other. Do not over-tighten. Seal all fastener heads with silicone sealant.</p>

IMPORTANT NOTE: To achieve DP50 ratings in clad nailing fin units, the #6 x 1-1/2" flat head screws holding the inside head stop must be replaced by #8 x 3" long flat head stainless steel screws (*installer must supply these screws*). The longer screws must be driven up through the head inside stop, the head jamb, and fastened securely into the framing. This screw change is not required for DP35 ratings on either clad or primed units.

Nailing Fin and Brick Mould Configurations

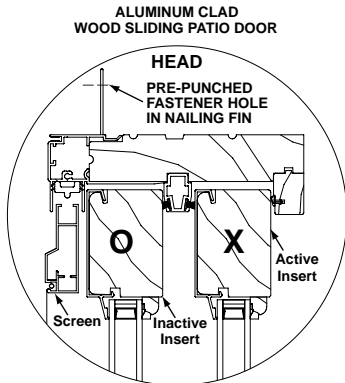

SIDE VIEW -- OX OPERATING CODE WITH NAILING FIN -- NO BRICK MOULD
FIGURE 1

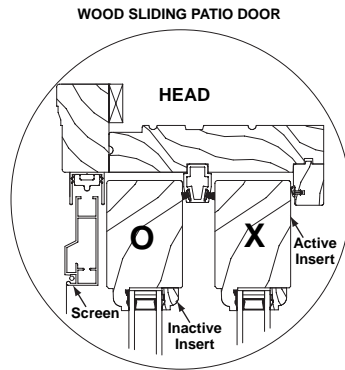

SIDE VIEW -- OX OPERATING CODE WITH BRICK MOULD
FIGURE 2

Gen - All

Door Operation

Door operation must be decided at time of order. Wood sliding patio doors are not reversible.

Patio door operation is viewed from the exterior of the unit. The following diagrams show available operating arrangements.

S = Stationary Insert O = Inactive Insert X = Active Insert

AVAILABLE OPERATING ARRANGEMENTS				
	One Panel	Two Panel	Three Panel	Four Panel
Standard	Stationary	--	OXS	OXXO
Optional	--	OX XO	XOS SXO SOX	--

1-Wide French Style Clad

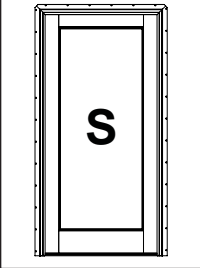

2-Wide French Style Clad



2-Wide French Style Clad

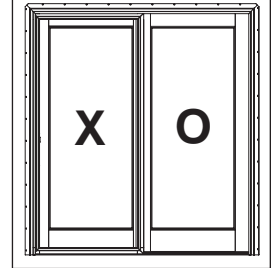

3-Wide French Style Clad

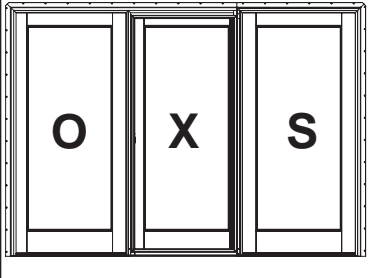

4-Wide French Style Clad

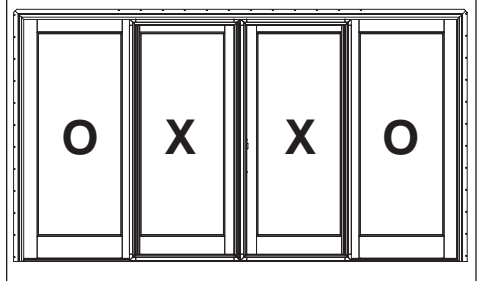

A Special Note About Masonry

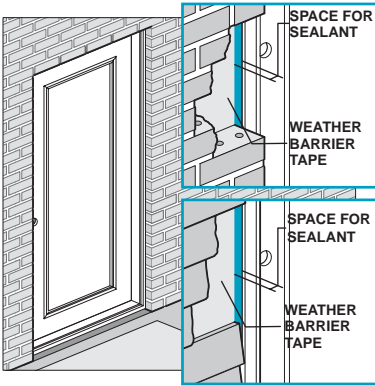

The perimeter joint between door exterior and the exterior building material must conform to siding manufacturers' recommendations. All masonry, stucco, or synthetic stucco systems require an expansion joint around the door perimeter that must be filled with sealant compatible with the building material and door components.

Expansion joint space should be no less than 3/8" and not greater than 1/2" unless stated otherwise by your siding manufacturer. If there is a conflict, follow siding manufacturer's guidelines.

Failure of this joint will cause structural damage unrelated to door performance.



Recognize this symbol. This is the Safety-Alert symbol. When you see this symbol be alert to the potential for personal injury or product damage.



DANGER



CUT HAZARD

- *Non-safety glass.
- *May cause serious injuries if broken.
- *Do not install where tempered safety glass is required.



WARNING

Weight of window and door unit(s) and accessories will vary. Use a reasonable number of people with sufficient strength to lift, carry and install window or door unit(s) and accessories. Always consider site conditions and use appropriate techniques when installing.



DANGER



Screen will not stop children, any one or anything from falling out window or door.

Keep children and objects away from open windows or doors.



DANGER

Falling from window or door opening may result in serious injury or death. DO NOT leave openings unattended when children are present.

IMPORTANT:

When accessories have been ordered, apply according to the directions **BEFORE** you install the unit OR prep the rough opening.

Check Rough Opening Size

FIGURE 1

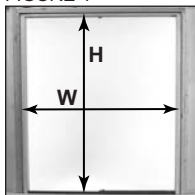

FIGURE 2

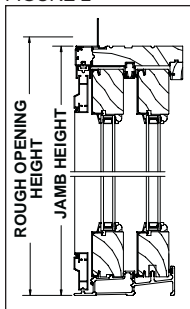

FIGURE 3

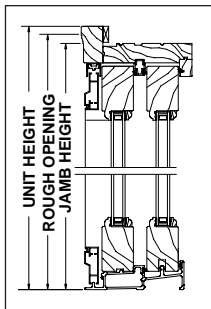

FIGURE 4

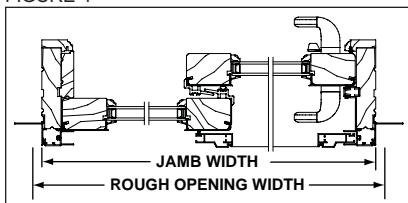
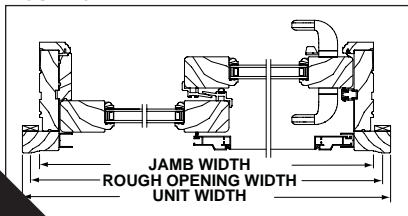

FIGURE 5



SAFETY INSTRUCTIONS

Read installation instructions completely before beginning procedure.



Wear gloves, safety glasses, goggles or eye shields appropriate to procedure.

Before you begin, check the following:

IMPORTANT: High-quality, exterior, neutral-cure, clear, silicone sealant (compatible with aluminum extrusion and exterior face of the wall) is to be used for all procedures in the following instructions which call for caulking or sealant.

IMPORTANT: Check to make sure you have the correct door type and the correct size door (Width and Height) for your rough opening (FIGURES 1 – 5).

1. Measure the rough opening to ensure that it is not more than 1/2" taller in overall Height or 3/4" wider in overall Width (FIGURE 1) than Jamb Height or Width (FIGURES 2, 3, 4, & 5).

IMPORTANT: If unit is to meet design pressure ratings, a maximum 1/4" shim space is required around perimeter. A shim space greater than 1/4" could result in lower product performance and may be considered non-compliant with certain building codes. If necessary, adjust rough opening so shim space is not greater than 1/4" on each side and the top.

NOTE: Doors do not require 1/4" shim space at the sill.

Check Rough Opening for Level and Square

FIGURE 1



1. Measure the opening diagonally from corner-to-corner (**FIGURES 1 & 1A**). The measurements should not differ more than 1/4".

2. Using a long level check side and sill for plumb and level (**FIGURES 2 & 2A**).

IMPORTANT: To ensure that the door panels operate smoothly, make sure that the sill is level and straight.

FIGURE 2

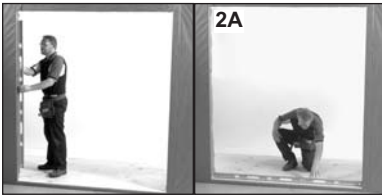

WARNING

Improper use of hand and power tools could result in personal injury and/or product damage. Follow equipment manufacturers' instructions for safe operation. Always wear safety glasses.

Straighten & Level Subfloor

FIGURE 1



1. Masonry installation requires a 2 x 6 sill plate to be present. Check sill for level (**FIGURE 1**).

2. To straighten and level the subfloor, identify the areas that are above level and countersink nails in the floor area that will be under the door (**FIGURE 2**).

3. Check for level as in (**FIGURE 1**). Plane area that will be under the door until it is straight and level (**FIGURE 3**).

FIGURE 2

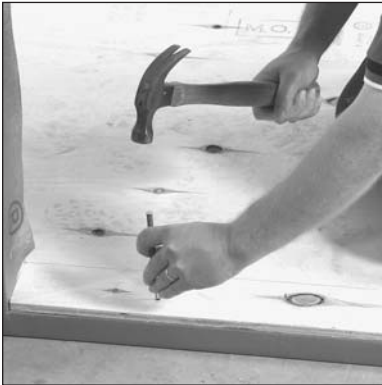
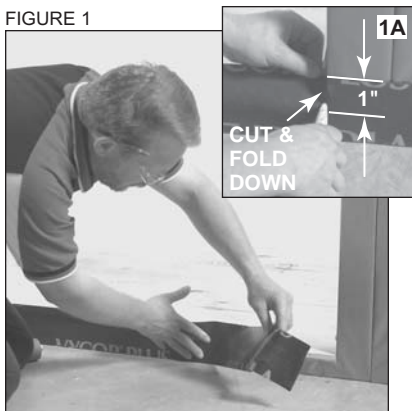

FIGURE 3



Sill Preparation

FIGURE 1



NOTE: If your structure has housewrap see the illustrations on Page 5 for installation techniques to preserve design pressure test ratings. Also perform steps in **Straiten & Level Subfloor** on Page 2.

IMPORTANT: You must complete **Steps 1 and 2** below for both nailing fin or brickmould units whether they are installed as DPR or non-DPR.

1. Cut a piece of weather barrier self-adhering tape 4" wide and as long as the opening width plus 8" (**FIGURE 1**). Apply to face of exterior wall so 1" extends above the opening and 4" extends beyond each side of the opening. Cut along the corners of rough opening and fold down onto the sill (**FIGURE 1A**).

FIGURE 2

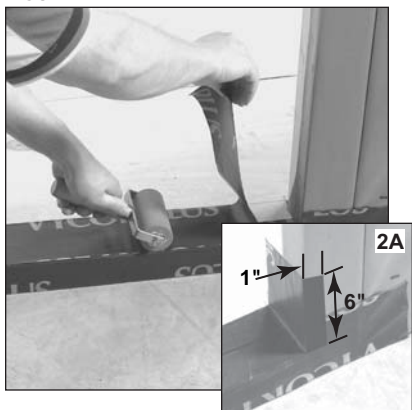

WARNING

Improper use of hand and power tools could result in personal injury and/or product damage. Follow equipment manufacturers' instructions for safe operation. Always wear safety glasses.

2. Apply a second continuous piece of weather barrier self-adhering tape on the top surface of the rough opening sill. Use a rubber roller to apply barrier to surface (**FIGURE 2**).

Cut barrier tape the thickness of the wall plus 1" and 12" longer than the width of the opening. Align flush with interior of the wall and extend edge of the tape 1" past the exterior wall surface (**FIGURE 2**). Start the piece (approximately 6") up the side of the rough opening and run it to the bottom of the opening, to the other side of the opening, and 6" up the other side (**FIGURE 2A**).

Rough Opening and Sill Preparation (cont.)

FIGURE 1



STOP – Read Following Note For Design Pressure Rating Considerations

NOTE: If your structure has housewrap and you must preserve design pressure ratings **DO NOT PERFORM STEP 1 BELOW.** See Page 5 for **required** techniques. Step 1 can be used where design pressure ratings are not a concern and ***must*** be used for ***brickmould non-DPR installations.***

Step 2 below must be completed for all DPR and non-DPR installations.

1. Apply a continuous 1/4" bead of high-quality sealant (compatible with nailing fin, brickmould and exterior face of wall) to the exterior face of the wall located 1/2" from the rough opening edge.

Caulk around the head and two vertical sides of the rough opening (FIGURE 1). When the door is installed the caulk bead must contact the nailing fin or brickmould continuously so it seals them against the face of the wall.

2. Apply two parallel beads of caulk on top of the subfloor membrane (FIGURE 2). One bead should be 1/2" from the wall's exterior surface. The second bead should be 1-3/4" back from the wall's exterior surface. These two caulk beads should be generous, continuous, and run the full width of the sill.

For DPR ratings continue on Page 5.

FIGURE 2

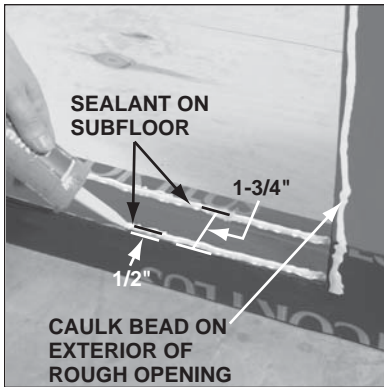

Housewrap & Caulking Rough Opening Details For Preserving Design Pressure Ratings On Structure With Housewrap

FIGURE 1

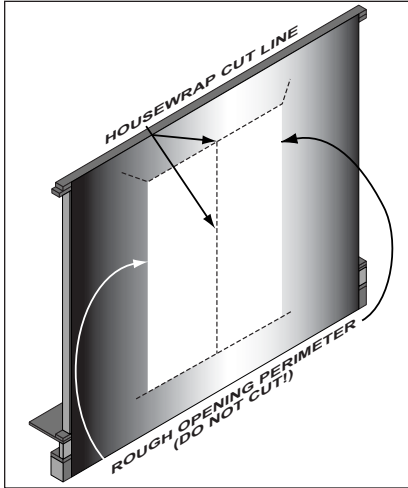

If your structure does not have housewrap, or you do not need to maintain DP Ratings, turn to installation pages that match your unit.

- Clad Nailing Fin – Page 6
- Wood Brickmould – Page 11
- 4-Wide Frame Assembly – Page 24

WARNING

Improper use of hand and power tools could result in personal injury and/or product damage. Follow equipment manufacturers' instructions for safe operation. Always wear safety glasses.

1. Cut housewrap as shown in (FIGURES 1 & 2).
2. Fold housewrap back and tape out of the way (FIGURE 2). Bare sheathing must be exposed.
3. Apply a continuous, generous bead of silicone sealant along head and vertical sides of rough opening perimeter. Locate sealant so it does not intrude into the rough opening and will also provide a continuous seal between sheathing and nailing fin or brickmould as well as door sill (FIGURE 3).

FIGURE 2

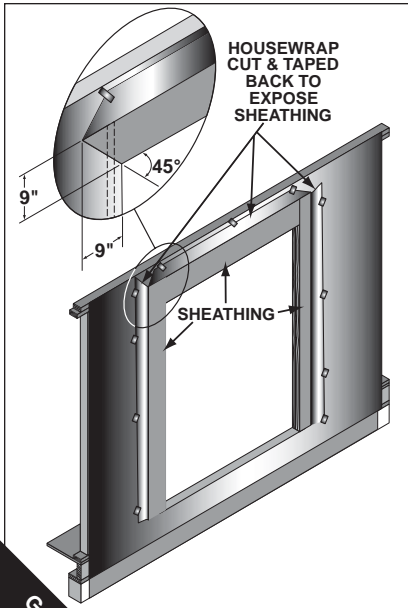
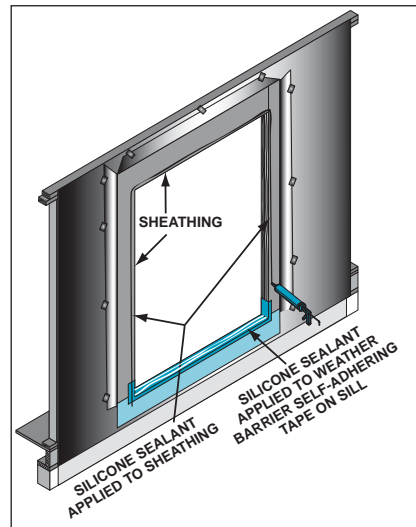

FIGURE 3



Door Installation For Clad Nailing Fin Units

FIGURE 1



FIGURE 2



FIGURE 3



FIGURE 4



⚠ WARNING

Weight of door unit(s) and accessories will vary. Use a reasonable number of people with sufficient strength to lift, carry and install door unit(s) and accessories. Always consider site conditions and use appropriate techniques when installing.

Note: 1, 2, and 3-Wide units ship with all inserts completely installed in the frame.

4-Wide units ship in a KD (knocked-down) condition and require assembly before installation. See instructions for 4-wide units starting on Page 24.

1. Remove all protective cardboard, strapping, other packing materials, and the hardware packages.
2. To equalize weight of the unit, slide active insert until it is fully shut.

IMPORTANT: If unit is to meet design pressure ratings, a maximum 1/4" shim space is required around perimeter. Unit must be secured with #8 steel screws, long enough to penetrate framing material by at least 1-1/2". See "Design Pressure Performance – Fastening Method" chart on Page v for screw spacing.

NOTE: If maintaining design pressure ratings are not a concern, roofing nails long enough to penetrate framing material by at least 1-1/2", may be used instead of screws.

IMPORTANT: Before proceeding, silicone sealant must be applied to the rough opening and sub sill as described on Page 4.

3. From the exterior, center and insert the door into the opening (FIGURE 1).

4. While holding door in place, level unit on the interior or exterior across the sill and head (FIGURES 2 & 3). To level the unit, place shims directly below the side jambs only.

IMPORTANT: Sill must be level and have solid support for its full length.

5. Secure one side top corner with a #8 steel screw long enough to penetrate framing material by at least 1-1/2" (FIGURE 4).

Door Installation For Clad Nailing Fin Units (cont.)

FIGURE 5



FIGURE 6



WARNING

Improper use of hand and power tools could result in personal injury and/or product damage. Follow equipment manufacturers' instructions for safe operation. Always wear safety glasses.

IMPORTANT: Take diagonal measurements across outside edges of frame.

6. Continue holding unit in place. Square and plumb jambs. Check both side-to-side and inside-to-outside (FIGURE 5). Measure from corner-to-corner to check for square (FIGURES 6 & 7).
7. Use a pry bar to slide bottom of unit left or right until diagonal measurements are exactly the same.
8. Secure other top corner and check again for level, plumb and square.
9. Use shims and a straightedge to straighten the side and top jamb. When straight, fasten through the nailing fin spacing screws as prescribed on Page v.

NOTE: If maintaining design pressure ratings are not a concern, roofing nails long enough to penetrate framing material by at least 1-1/2", may be used instead of screws.

FIGURE 7



Housewrap & Caulking Finishing Details For Preserving Design Pressure Ratings On Structure With Housewrap

FIGURE 1

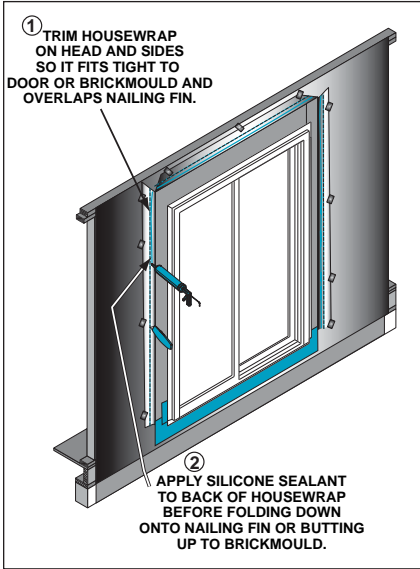

If your structure does not have housewrap continue on Page 9.

WARNING

Improper use of hand and power tools could result in personal injury and/or product damage. Follow equipment manufacturers' instructions for safe operation. Always wear safety glasses.

Trim and reseal housewrap to new door after door is installed according to the instructions on Pages 6 and 7.

See (FIGURE 1) for Steps 1 through 3.

1. One section at a time, untape and fold housewrap over nailing fin and up against the door frame. Use a utility knife or scissors and carefully trim housewrap alongside the door frame or brickmould. When trimmed, housewrap must lay flat against sheathing, overlap the nailing fin, and fit tightly against the door frame or brickmould. After trimming and dry fitting, tape housewrap back out of the way so bottom side is exposed. Repeat for each section of housewrap.

2. Apply a continuous bead of caulk to the back side of the housewrap along the edge that will butt against the door frame or brickmould. Also caulk along edges of any additional seams and at diagonal corner cuts.

3. Fold each caulked section down onto sheathing, overlapping the nailing fin and butting it tightly to the door frame or brickmould. Smooth out all wrinkles and bulges.

Repeat Steps 2 and 3 for each section.

4. Finish by inspecting each housewrap seam making sure each seam is sealed with silicone sealant (FIGURE 2).

FIGURE 2

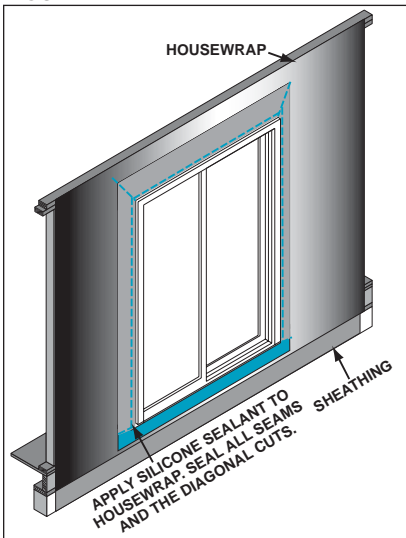

To continue your installation proceed to "Square and Straighten The Interior" on Page 16.

Weather Barrier Self-Adhering Tape Application – Units With Nailing Fin

FIGURE 1

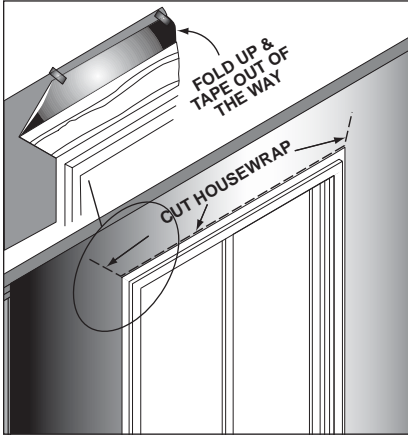
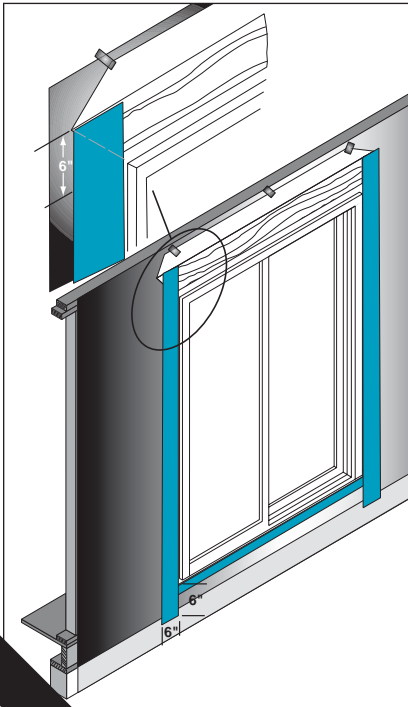

FIGURE 2



NOTE: The Following **Weather Barrier Self-Adhering Tape** procedures do not apply if you have just completed **Housewrap & Caulking Finishing Details For Preserving Design Pressure Ratings On Structure With Housewrap** on previous page. *You should continue your installation on Page 16.*

1. Cut housewrap or building paper parallel to head nailing fin and at an angle to each corner to create a flap (FIGURE 1).
2. Fold flap up out of the way and tape to the wall with cloth tape (FIGURE 1).
3. Cut two pieces of high-quality weather barrier self-adhering tape that are 6" wide and 12" taller than the door (FIGURE 2). Start at either the top or bottom, about 6" above or below the door. Apply tape close to the door side frame and work to opposite end. Tape **must** cover the entire nailing fin, including the installation holes, the joint between the fin and the building's sheathing **and** extend at least one additional inch out onto the exterior wall. Use a rubber roller to get good contact with the substrate.

Continued on next page.

Weather Barrier Self-Adhering Tape Application – Units With Nailing Fin (cont.)

FIGURE 3

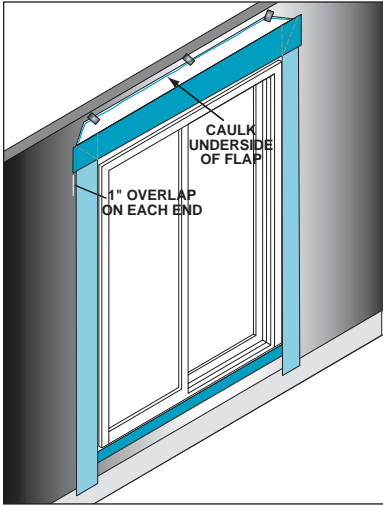

4. Cut weather barrier tape for the top. It must be long enough to overlap both side pieces by at least 1" (FIGURE 3). Make piece tall enough to cover the entire nailing fin, including the installation holes, the joint between the fin and the building's sheathing **and** extend at least one additional inch out onto the sheathing.

5. Apply weather barrier tape to top of door (FIGURE 3).

6. Apply clear silicone sealant to underside of housewrap or building paper flap, along edges of seams (FIGURE 3).

7. Fold housewrap or building paper flap down over the top piece of weather barrier tape (FIGURE 4). Use a rubber roller, on top of flap, to smooth and spread sealant applied in Step 6.

8. Cut two pieces of weather barrier sealing tape. Make sealing tape 4" longer than diagonal seams. Apply tape over the diagonal seams so that 2" of tape extends beyond the ends of each seam (FIGURE 4).

FIGURE 4

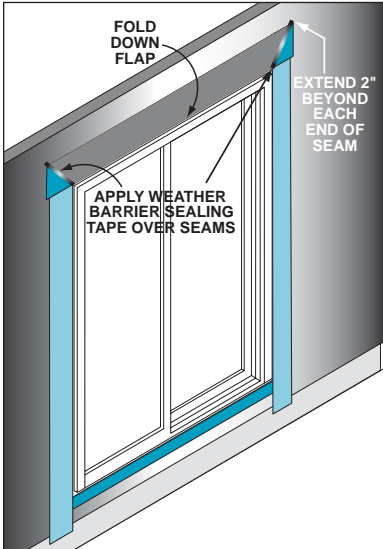

Door Installation For Wood Brickmould Units

FIGURE 1



FIGURE 2



FIGURE 3



FIGURE 4



WARNING

Weight of door unit(s) and accessories will vary. Use a reasonable number of people with sufficient strength to lift, carry and install door unit(s) and accessories. Always consider site conditions and use appropriate techniques when installing.

Note: 1, 2, and 3-Wide units ship with all inserts completely installed in the frame.

4-Wide units ship in a KD (knocked-down) condition and require assembly before installation. See instructions for 4-wide units on Page 24.

1. Remove all protective cardboard, strapping, other packing materials, and the hardware packages.
2. To equalize weight of the unit, slide active insert until it is fully shut.

IMPORTANT: Before proceeding, silicone sealant must be applied to the rough opening and sub sill as described on Page 4.

3. From the exterior, center and insert the door into the opening (FIGURE 1).

4. While holding door in place, level unit on the interior or exterior across the sill and head (FIGURES 2 & 3). To level the unit, place shims directly below the side jambs only.

IMPORTANT: Sill must be level and have solid support for its full length.

NOTE: Drilling pilot holes for either screws or nails will help prevent wood brick mould from splitting and cracking.

IMPORTANT: If unit is to meet design pressure ratings, a maximum 1/4" shim space is required around perimeter. Unit must be secured with #8 stainless steel screws, long enough to penetrate framing material by at least 1-1/2". See "Design Pressure Performance – Fastening Method" chart on Page v for screw spacing.

5. Secure one side top corner with a #8 stainless steel screw long enough to penetrate framing material by at least 1-1/2" (FIGURE 4).

NOTE: If maintaining design pressure ratings are not a concern, galvanized casing nails, long enough to penetrate framing material by at least 1-1/2", may be used instead of screws.

Door Installation For Wood Brickmould Units (cont.)

FIGURE 5



FIGURE 6



WARNING

Improper use of hand and power tools could result in personal injury and/or product damage. Follow equipment manufacturers' instructions for safe operation. Always wear safety glasses.

IMPORTANT: Take diagonal measurements across outside edges of frame.

6. Continue holding unit in place. Square and plumb jambs. Check both side-to-side and inside-to-outside (FIGURE 5). Measure from corner-to-corner to check for square (FIGURES 6 & 7).
7. Use a pry bar to slide bottom of unit left or right until diagonal measurements are exactly the same.
8. Secure other top corner and check again for level, plumb and square.
9. Use shims and a straightedge to straighten the side and top jamb. When straight, fasten through the wood brick mould spacing stainless steel screws 12" on center around head and sides.

NOTE: If maintaining design pressure ratings are not a concern, galvanized casing nails, long enough to penetrate framing material by at least 1-1/2", may be used instead of screws.

FIGURE 7



Drip Cap Installation – Wood Brickmould Units

FIGURE 1



FIGURE 2



WARNING

Improper use of hand and power tools could result in personal injury and/or product damage. Follow equipment manufacturers' instructions for safe operation. Always wear safety glasses.

1. Measure and cut a drip cap that is as long as the top brickmould.
2. Apply a continuous 1/4" bead of high-quality, exterior, neutral-cure clear silicone sealant (compatible with wood and exterior face of the wall) to the exterior face of the wall and brickmould (**FIGURE 1**). Locate caulk bead on the wall above the brickmould so the drip cap vertical leg will seal against the caulk. Caulk must be as long as the drip cap.
3. Place drip cap on top of brickmould (**FIGURE 2**) and center its length on the brickmould. Push tightly down against brickmould and imbed the vertical leg into the bead of caulk.
4. Nail drip cap in place with galvanized roofing nails long enough to penetrate framing members by at least 1-1/2" (**FIGURE 3**). Place nails every 12 to 16 inches along drip cap's length.

FIGURE 3



Weather Barrier Self-Adhering Tape Application – Units With Wood Brickmould

FIGURE 1

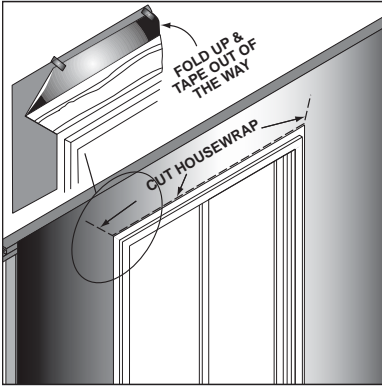
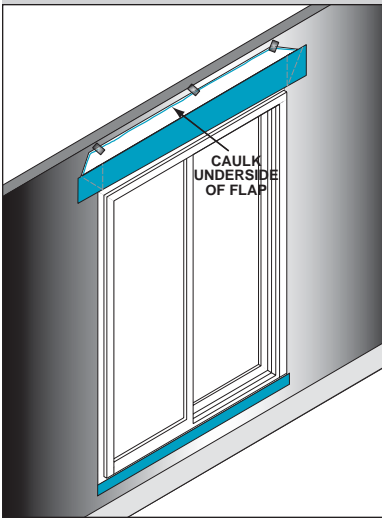

FIGURE 2



WARNING

Improper use of hand and power tools could result in personal injury and/or product damage. Follow equipment manufacturers' instructions for safe operation. Always wear safety glasses.

1. Use a utility knife to cut a flap in the housewrap or building paper above the drip cap, the entire width of the drip cap. Cut the corners at a diagonal (**FIGURE 1**). Fold flap up and temporarily tape out of the way.
2. Cut a piece of weather barrier self-adhering tape 6 inches tall and long enough to cover the drip cap **PLUS 12"** (**FIGURE 2**).
3. Center weather barrier tape over the drip cap so 6" of tape extends on either side of the drip cap. Tape must cover the nail heads securing the drip cap and extend up onto the sheathing.
4. Use a rubber roller, on top of weather barrier tape, to firmly seat the horizontal piece of tape.
5. Apply clear silicone sealant to underside of the building paper or housewrap flap, along edges of the seams (**FIGURE 2**).
6. Fold housewrap or building paper flap down over the weather barrier tape (**FIGURE 3**). Use a rubber roller on top of flap to smooth and spread sealant applied in Step 5.
7. Cut two pieces of weather barrier sealing tape. Make sealing tape 4" longer than the diagonal seams. Apply tape over the diagonal seams so that 2" of tape extends beyond the ends of each seam (**FIGURE 3**).

FIGURE 3

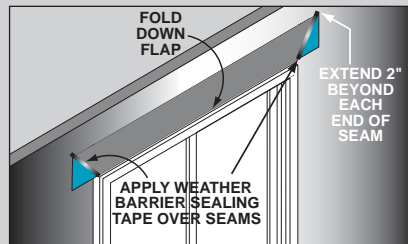

Housewrap & Caulking Finishing Details For Preserving Design Pressure Ratings On Structure With Housewrap

FIGURE 1

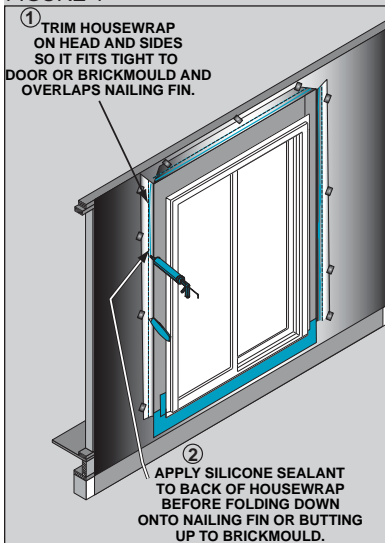
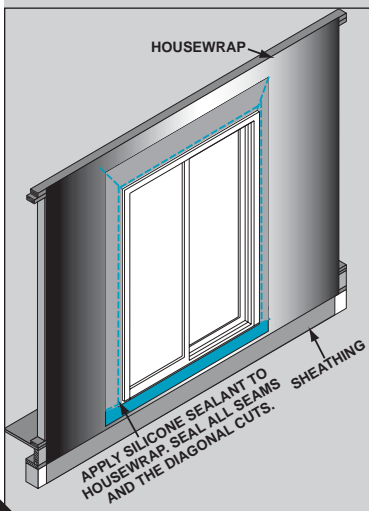

FIGURE 2



If your structure does not have housewrap continue on Page 16.

WARNING

Improper use of hand and power tools could result in personal injury and/or product damage. Follow equipment manufacturers' instructions for safe operation. Always wear safety glasses.

Trim and reseal housewrap to new door after door is installed according to the previous instructions.

See (FIGURE 1) for Steps 1 through 3.

1. One section at a time, untape and fold housewrap over nailing fin and up against the door frame. Use a utility knife or scissors and carefully trim housewrap alongside the door frame or brickmould. When trimmed, housewrap must lay flat against sheathing, overlap the nailing fin, and fit tightly against the door frame or brickmould. After trimming and dry fitting, tape housewrap back out of the way so bottom side is exposed. Repeat for each section of housewrap.

2. Apply a continuous bead of caulk to the back side of the housewrap along the edge that will butt against the door frame or brickmould. Also caulk along edges of any additional seams and at diagonal corner cuts.

3. Fold each caulked section down onto sheathing, overlapping the nailing fin and butting it tightly to the door frame or brickmould. Smooth out all wrinkles and bulges.

Repeat Steps 2 and 3 for each section.

4. Finish by inspecting each housewrap seam making sure each seam is sealed with silicone sealant (FIGURE 2).

To continue your installation proceed to "Square and Straighten The Interior" on Page 16.

Square and Straighten the Interior – All Installations

FIGURE 1



FIGURE 2



FIGURE 3

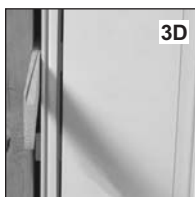

⚠ WARNING

Improper use of hand and power tools could result in personal injury and/or product damage. Follow equipment manufacturers' instructions for safe operation. Always wear safety glasses.

1. Shim the top and bottom ends of the side jamb on the left or right to get the diagonal measurements (**FIGURES 1 & 2**) of the entire door assembly exactly the same.

2. Using a level as a straightedge, place shims between the frame and the rough opening to straighten the side jambs (**FIGURE 3D**).
3. Loosely insulate between the door frame and rough opening.

IMPORTANT: Straighten and support mull unit sills with wood shims under the ends of the jambs.

IMPORTANT: Do not over pack insulation.

IMPORTANT: Do not use expandable foam.

Removing Screen, Installing Screen – All Installations

FIGURE 1

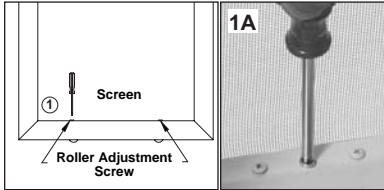

FIGURE 2

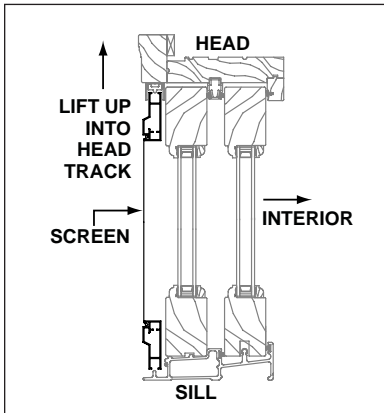
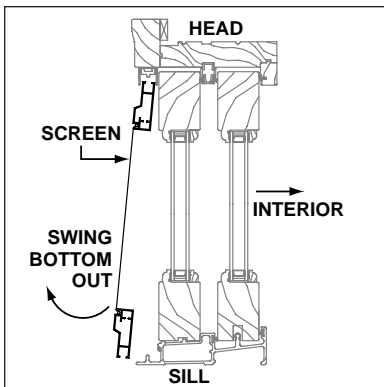

FIGURE 3



WARNING

Improper use of hand and power tools could result in personal injury and/or product damage. Follow equipment manufacturers' instructions for safe operation. Always wear safety glasses.

Removing Screen

1. Retract top and bottom screen rollers by turning the screen roller adjustment screws counterclockwise with a Phillips screwdriver (FIGURES 1 & 1A).
2. Grasp sides of screen and lift gently until top is fully up into the head track (FIGURE 2).
3. While holding screen up into head track, carefully pull screen outward until screen bottom clears sill screen support (FIGURE 3).

Installing Screen

1. Retract top and bottom screen rollers by turning the screen roller adjustment screws counterclockwise with a Phillips screwdriver (FIGURES 1 & 1A).
2. Grasp sides of screen and lift top into head frame screen channel (FIGURE 2).
3. Carefully push screen inward until it is in place in the frame channel and the rollers are properly positioned on the screen track.

Screen Adjustment – All Installations

FIGURE 4

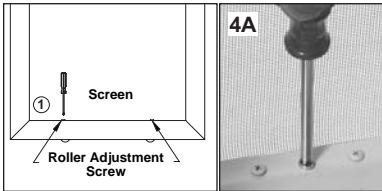

WARNING

Improper use of hand and power tools could result in personal injury and/or product damage. Follow equipment manufacturers' instructions for safe operation. Always wear safety glasses.

Screen Adjustment

To adjust screen for smooth operation use a Phillips screwdriver on the adjustment screw in each screen roller (FIGURES 4 & 4A). Turn clockwise to extend the roller or turn counterclockwise to retract the roller. There are rollers at each corner, both top and bottom. For best results all rollers should be adjusted.

NOTE: To raise screen, top rollers need to be retracted and bottom rollers extended. To lower screen top rollers need to be extended and bottom rollers retracted.

Installing Screen Keeper – All Installations

FIGURE 5

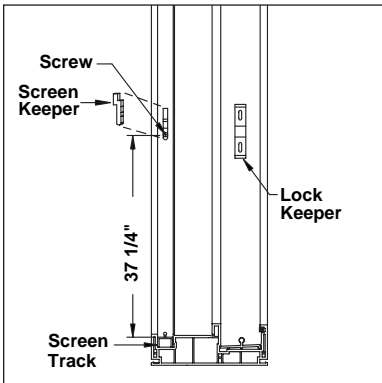

Install Screen Keeper

1. Measure 37-1/4" upward from flat top of screen track and mark the side frame at this point. Mark should be centered in the frame channel (FIGURE 5).
2. Position screen keeper so bottom screw hole is centered over the mark on the side frame.
3. Fasten bottom screw through keeper and into mark on frame. Fasten top screw. Do not tighten screws completely.
4. Close screen and activate screen lock to check for correct alignment. Adjust keeper up or down, if necessary, for proper locking, then tighten screws.

Remove & Install Active Insert Adjust Active Insert – All Installations

FIGURE 1

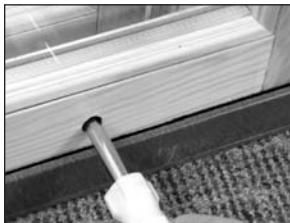

FIGURE 2



IMPORTANT:

To achieve DP50 ratings in clad units, replace head inside stop screws (FIGURE 2) with #8 x 3" long stainless steel screws (not provided).

FIGURE 3



FIGURE 4



FIGURE 5



WARNING Inserts are heavy. Use caution when handling to avoid injury or damage. Use adequate number of people to handle insert.

CAUTION Prevent damage to sill track! Check roller position (one set on each bottom side of each active insert) before moving active insert. Insert must be fully supported by roller mechanism. Extend or retract rollers to achieve insert support.

IMPORTANT: For best results adjust both sets of rollers at the same time.

Adjust Active Insert – Turn adjusting screw (FIGURE 1):

Clockwise – Lower Rollers – Raise Insert
Counterclockwise – Raise Rollers – Lower Insert
Use roller adjustment screw (FIGURE 1) to raise or lower insert to achieve smooth operation and to keep insert level and plumb.

NOTE: Vinyl plugs are provided to cover adjustment screw holes. These plugs can be stained to match your insert.

Removing Active Insert

1. Slide active insert open enough to completely clear side jamb channel. Slide panel far enough open so you can grasp both sides.
2. Use a Phillips head screwdriver to fully retract insert rollers. Turn screw counterclockwise.
3. Use a Phillips screwdriver to remove head inside stop (FIGURE 2).
4. While holding both sides of insert tilt the insert top toward you (FIGURE 3).
5. Lift insert off sill track.

Installing Active Insert

IMPORTANT: Clean sill before installing active insert.

1. With insert upright and rollers (FIGURE 4) down, position insert close to its side frame. Lift insert up onto the sill sill track. Be sure interlock will properly engage inactive insert.
2. Carefully push top of insert away from you until it is positioned vertically in the frame channel.

NOTE: Both sets of rollers must seat correctly on the sill track so the insert operates smoothly. Groove of rollers must rest on crown of sill track (FIGURE 5).

3. Slide insert to the fully closed position so the interlocks engage and the insert is secure.
4. While holding insert in place, use a Phillips head screwdriver to lower insert rollers. Turn screw clockwise until rollers support insert. **Adjust both sets of rollers.**
5. Install head inside stop. 6. Install vinyl hole plugs.

Install Handles and Lock – All Installations

FIGURE 1



FIGURE 2

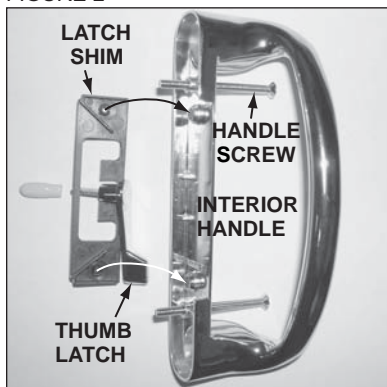

FIGURE 3



WARNING

Improper use of hand and power tools could result in personal injury and/or product damage. Follow equipment manufacturers' instructions for safe operation. Always wear safety glasses.

WARNING Inserts are heavy. Use caution when handling to avoid injury or damage. Use adequate number of people to safely handle insert.

- NOTE:** At this point the active insert must be:
1. Properly installed in the door frame.
 2. Rollers properly adjusted.

Follow previous insert installation and roller adjustment procedures.

1. From the inside, insert a plastic bushing into the top and bottom holes in door stile (**FIGURE 1**). Seat bushings fully.

NOTE: If you ordered a key lock it will be pre-assembled to the handle. The handle with the key housing mounts to the outside of the structure.

The interior handle has a thumb latch to operate the locking mechanism.

2. Assemble latch shim, thumb latch and interior handle as shown (**FIGURE 2**). Remove and discard plastic protector from thumb latch. Firmly seat latch shim in holes on interior handle with thumb latch in center slot (**FIGURE 3**).
3. Insert handle parts into door stile. Interior handle to inside; exterior handle to outside with curve of handles pointing toward the glass (**FIGURE 4**).

FIGURE 4



Install Handles and Lock – All Installations (cont.)

FIGURE 5



FIGURE 6



FIGURE 7



FIGURE 8

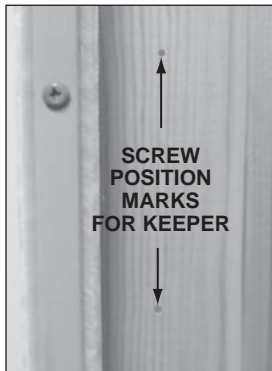

4. Secure handle assemblies with handle screws inserted from the interior.

5. Flip thumb latch UP to lock active insert. Flip thumb latch DOWN to unlock active insert.

6. Locate panel keeper marker (FIGURE 6).

7. Mount to latch by flipping thumb latch to unlock. Align notches on panel keeper marker with latching hooks. While holding marker in position between latching hooks, flip thumb latch to locked position (FIGURE 7) to hold marker in place.

8. Firmly move active insert against side jamb so marker makes small dents in side jamb to locate screw position for keeper (FIGURE 8).

9. Align keeper with marks on side jamb and screw in place through slotted holes (FIGURE 9). Install two screws. Close active insert and operate thumb latch to check operation of latch and keeper alignment.

If necessary, loosen screws in keeper and adjust keeper up or down. Check latch operation with each keeper adjustment. When latch and keeper are properly aligned tighten two screws and add the two additional screws through other slotted screw holes in keeper.

Additional adjustment can be made by moving the latch hooks in or out by turning screws on latch face (FIGURE 10).

FIGURE 9



FIGURE 10

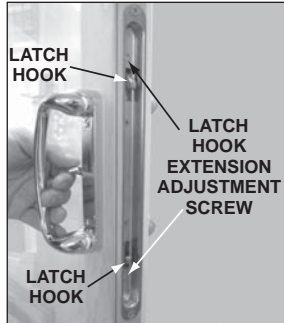

Recommended Finishing Instructions – All Installations



WARNING

Always follow chemical manufacturers' safety instructions when using chemicals to avoid injury or illness.

For Vinyl and Aluminum Surfaces

Vinyl and aluminum surfaces may be cleaned with mild soap and water. Hard to remove stains and mineral deposits may be removed with mineral spirits.

- **Do NOT** clean with gasoline, diesel fuel, solvent based, or petroleum based products.
- **Do NOT** use abrasive materials against vinyl, aluminum, or glass surfaces.
- **Do NOT** scrape or use tools that might damage the surface.
- **Do NOT** paint vinyl or aluminum surfaces.

For Bare Wood Surfaces – [See Next Page For Additional Information About Doors]

For best results, wood should be sealed immediately upon installation or upon receipt, especially if unit is being stored for ANY length of time.

1. Remove all construction and adhesive label residue with mineral spirits before finishing.
2. Lightly sand surfaces being finished with 180 grit or finer sandpaper. Be careful not to scratch the glass.
3. After sanding, clean-off sanding dust using lacquer thinner applied to a cloth so the cloth is slightly damp. Let surface dry completely.

-If a painted surface is desired:

- If a wood unit is delivered with factory-applied primer paint, it may be painted without repriming, providing the finish paint coat is applied within six (6) months of unit installation.
 - If a factory-primed wood unit requires repriming contact your customer service representative for help in selecting a primer compatible with the factory applied material.
 - Factory-applied Accentials™ color system finishes in standard, designer or custom colors do not require additional painting. For “touch up” paint specifications contact your customer service representative.
1. An unprimed wood unit **requires priming**. Use only oil-based primer. Use compatible oil or water-based finish coats. Refer to the primer and paint manufacturers' instructions.
 2. When priming bare wood or repriming, cover all exposed wood surfaces. Priming all exposed surfaces helps prevent end splitting, warping and/or checking.
 3. Once primed, apply two (2) coats of paint (again on all exposed sides) to each item.

-If a stained surface is desired:



If no sealer is applied over stain, the wood will weather very rapidly and defects will occur. Apply at least two (2) coats of sealer.

1. Use only oil-based stain. A gel stain is easier to apply as it does not easily run or drip. The clear top coats may be oil or water-based. Apply at least two top coats of sealer or varnish.
- A pre-stain wood conditioner, applied before staining, will help softer woods like pine absorb stain more evenly. Apply both wood conditioner and desired stain according to the manufacturers' instructions.
2. Apply one (1) coat of sealer to the stained surface and let dry. Using a spar (marine) varnish as a sealer provides extra protection against sunlight and moisture. Let sealer dry completely.
3. Before applying the next finish coat, make sure the previous coat is completely dry. Then lightly sand previous finish coat with 180 grit or finer sandpaper. Clean off all sanding dust and wipe surfaces with a tack cloth.
4. Apply next coat of desired finish to surface and let dry. Apply only one coat at a time.
5. For any additional coats of finish, repeat steps 3 and 4.

-For a clear (natural) finish: Follow Steps 1, 2, and 3 under “Bare Wood” and Steps

Recommended Finishing Instructions (cont.)

Door Inserts

All active and removable door inserts, whether sliding or hinged, must be removed from the door frame after installation so they can be properly sealed (**FIGURE 1**). See preceding insert removal instructions.

Both clad and wood door units have bare wood on the top and bottom of the inserts. Paint or varnish these areas as you would all of the other

exposed exterior wood. Follow procedures outlined in "Recommended Finishing Instructions" on previous page.

CAUTION Do not get paint, varnish or sealer in the rollers on the bottom of sliding inserts. Rollers must be kept clean so they will rotate freely.

CAUTION Keep all sealers off weatherstrip or bottom sweeps.

FIGURE 1

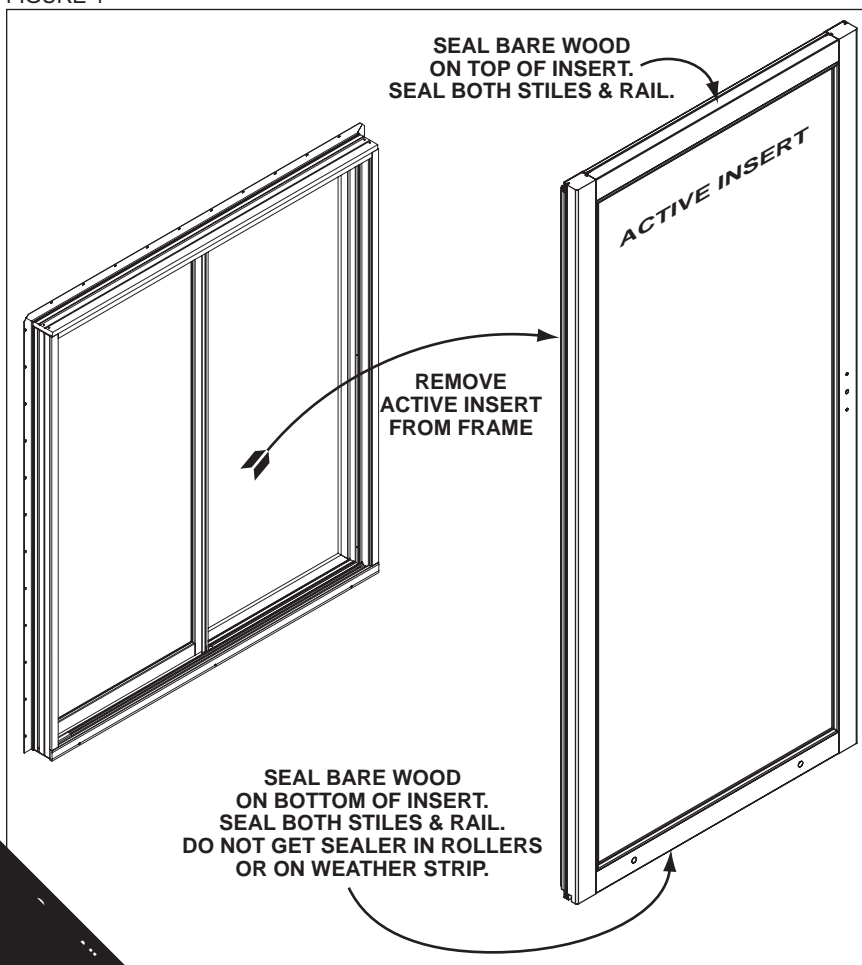

4-Wide Door Frame – General

FIGURE 1

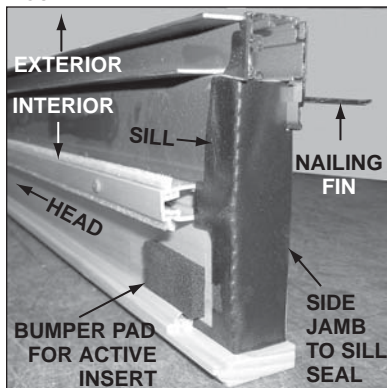
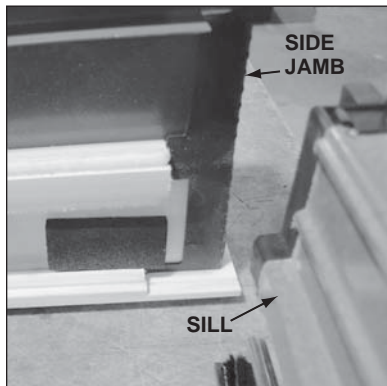

FIGURE 2



WARNING

Improper use of hand and power tools could result in personal injury and/or product damage. Follow equipment manufacturers' instructions for safe operation. Always wear safety glasses.

4-Wide patio doors are shipped unassembled. Your unit's package should contain:

- 2 Active Inserts
- 2 Inactive Inserts
- 1 Head Jamb
- 2 Side Jamb
- 1 One-Piece Sill
- 1 Set of Insert Handles
- Miscellaneous Assembly Hardware

As a minimum for assembly you will need to supply:

- Electric or Battery Drill With Drill and Screwdriver Bits
 - Clear Silicone Sealant
 - Sealant (Caulking) Gun
 - Measuring Tape
 - Framing Square
 - Wood Glue
 - Wood Shim (3/4"W x 5/32"Thick x L)
- L=Inactive Panel Width Minus 1-3/4"

General Instructions

1. Assembly area must be smooth, flat and large enough to accommodate entire door frame and allow working space around perimeter of frame.
2. Area should be free of debris and abrasive material to eliminate damage to components.
3. Carefully unpack door unit and inventory contents. If any components are missing obtain replacements before starting assembly and installation.
4. **General sequence** is to assemble the frame, install inserts in the frame, install frame in the rough opening, and then install handle/lockset.
5. As frame parts are unpacked and organized for assembly, place parts in proper orientation to one another (**FIGURES 1 & 2**).

NOTE: Assembly for 4-wide frames, whether aluminum clad or wood brickmould, is almost identical. What differs is how the brickmould head and side jamb corners are secured.

The following assembly instructions should be followed for either style unit.

A gray background is used to highlight variations that must be followed for wood brickmould units.

Assemble 4-Wide Door Frame

FIGURE 1

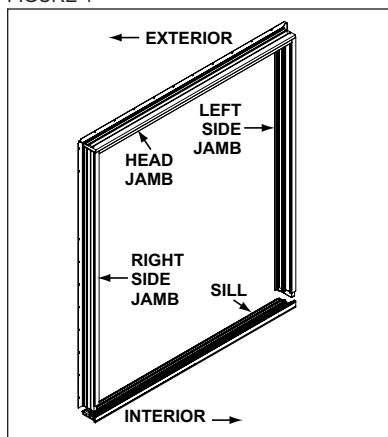

FIGURE 2



1. Find the head jamb, left side jamb, right side jamb, sill and screws for the frame assembly (**FIGURE 1**). If your unit is aluminum clad you will also need the two corner keys.

Screws Needed:

Sill to Side Jamb

#6x2-1/4" Phillips Flat Head 410 Stainless - 3 per jamb

Side Jamb to Sill

#10x1-1/2" Phillips Pan Head 18-8 Stainless - 1 per side jamb

Head to Side Jamb

#8x2" Phillips Flat Head 401 Stainless - 3 per jamb

Aluminum Clad Mitered Corners

#6x2-1/4" Phillips Flat Head 410 Stainless - 1 per corner

Brickmould Mitered Corners

#8x2-1/2" Flat Head Drywall Screw - 1 per corner

2. Lay all frame components on a smooth, level, flat surface. Turn each piece upright (exterior side up).

3. "Dry-Fit" all pieces. Check that parts fit properly. Also look at surfaces for damage. Fix problems before proceeding.

4. Lay head jamb down flat with exterior up. Drill three 3/32" diameter pilot holes through head jamb (**FIGURE 2**). Locate holes so they line up with side jamb. Drill pilot holes in both ends of head jamb.

4a. On wood brickmould units apply wood glue along log face of mitered corners (**FIGURE 3**).

FIGURE 3



Assemble 4-Wide Door Frame (cont.)

FIGURE 4

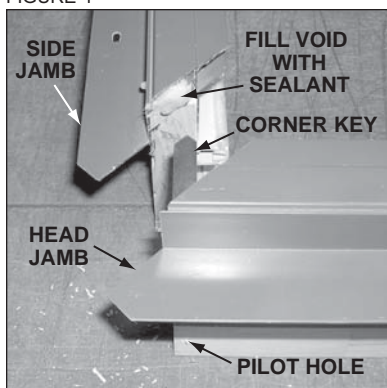
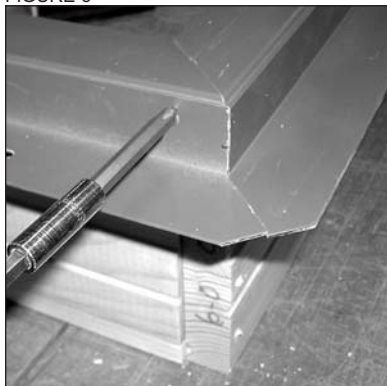

FIGURE 5



FIGURE 6



WARNING

Improper use of hand and power tools could result in personal injury and/or product damage. Follow equipment manufacturers' instructions for safe operation. Always wear safety glasses.

Note: High-quality, exterior, neutral-cure, clear, silicone sealant (compatible with aluminum extrusion) is to be used for all procedures in the following instructions which call for caulking or sealant.

For Clad Nailing Fin Units Only

See next page for wood brickmould units.

5. Fill void in side jamb cladding with sealant (FIGURE 4).
6. Insert corner key into corner key slot in head jamb (FIGURE 4).
7. Move head and side jambs so corner key is inserted into corner key slot in side jamb.
8. Clamp or securely hold side and head jamb in alignment.
9. Install one #8 x 2" Phillips flat head 401 stainless steel screw through a head jamb pilot hole. Drive screw down into side jamb (FIGURE 5).
10. Now move to side jamb and install one #6 x 2-1/4" Phillips flat head 410 stainless steel screw through side jamb extrusion (FIGURE 6).
11. Check and adjust side to head jamb alignment and then secure head jamb to side jamb by installing remaining two #8 x 2" Phillips flat head 401 stainless steel screws through head jamb pilot holes (FIGURE 7).
12. Repeat Steps 5 through 11 for other head and side jamb joint.

FIGURE 7



Assemble 4-Wide Door Frame (cont.)

FIGURE 4BM



FIGURE 5BM

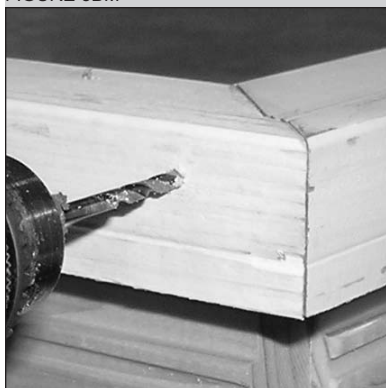

FIGURE 6BM



For Wood Brickmould Units Only

5. Move head and side jambs together so mitered corner pieces align. Clamp or securely hold side and head jamb in alignment.
6. Install one #8 x 2" Phillips flat head 401 stainless steel screw through one of the three head jamb pilot holes. Drive screw down into side jamb (FIGURE 4BM).
7. Drill and counter sink pilot hole in head jamb brickmould for #8 x 2-1/2" flat head drywall screw (FIGURE 5BM).
8. Install remaining two #8 x 2" Phillips flat head 401 stainless steel screws through head jamb pilot holes (FIGURE 6BM).
9. Apply drywall screw to secure brickmould corner joint (FIGURE 7BM).
10. Fill brickmould counter sunk screw holes with exterior grade filler (FIGURE 8BM).
11. Repeat Steps 5 through 11 for other head and side jamb brickmould joint.

FIGURE 7BM



FIGURE 8BM



Assemble 4-Wide Door Frame (cont.)

FIGURE 1

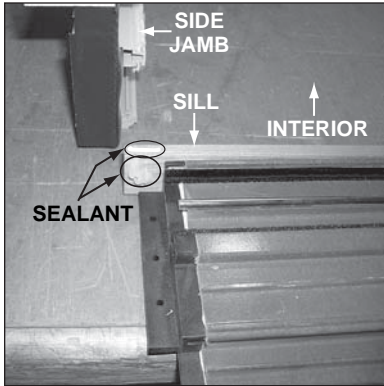
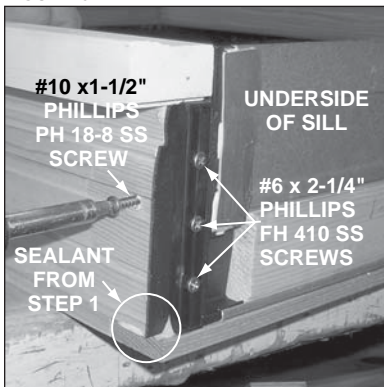

FIGURE 2



FIGURE 3



WARNING

Improper use of hand and power tools could result in personal injury and/or product damage. Follow equipment manufacturers' instructions for safe operation. Always wear safety glasses.

Sill To Side Jamb Assembly

NOTE: Procedure is the same whether unit is aluminum clad or has wood brickmould.

1. With sill laying face up, apply generous amount of sealant on each end as shown in (FIGURE 1).
2. Pull sill and side jamb together. Tip sill so exterior edge faces up. Align side jamb with mating parts of sill. While holding pieces securely together fasten sill to side jamb with one #6 x 2-1/4" Phillips flat head 410 stainless steel screw (FIGURE 2).
3. While holding sill and side frame in alignment, attach side frame to sill with a #10 x1-1/2" Phillips pan head 18-8 stainless steel screw through side frame pilot hole into sill end plug (FIGURE 3).
4. Finish securing one side of sill to side jamb by applying two more #6 x 2-1/4" Phillips flat head 410 stainless steel screws through sill into side jamb (FIGURE 3).
5. Repeat Step 2, 3, and 4 for other side jamb to sill joint.

4-Wide – Inactive Insert Installation

FIGURE 1

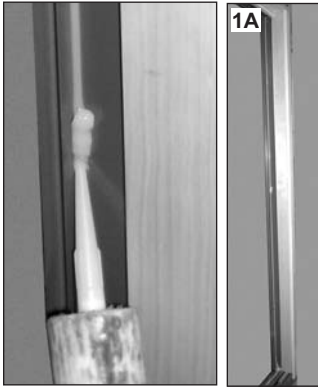
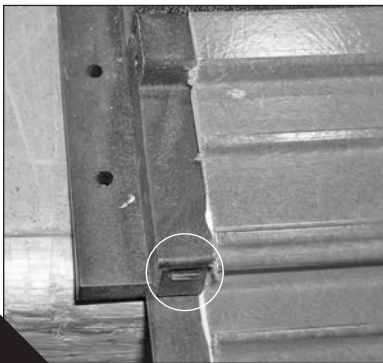

FIGURE 2



FIGURE 3



1. Stand completed frame up so sill is down and it rests on a firm, level, uniformly supporting surface.
2. Brace frame with sturdy temporary supports so inactive inserts can be installed.



DANGER

Temporary supports must hold frame securely to:

- a. Prevent personal injury.
- b. Prevent property damage.
- c. Keep frame and inserts aligned as inserts are installed.

NOTE: Procedures given for inactive insert installation are for one side. You could alternate sides with each step and install both inserts simultaneously.

3. Remove any packing material, hardware packages, and shipping fasteners.
4. Brush off loose dirt and debris. Sealant must adhere to frame's surface. If frame is dirty wash with mild detergent, rinse and dry thoroughly.
5. Using a high-quality, exterior, neutral-cure, clear, silicone sealant (compatible with frame and panel surfaces) lay a continuous bead along vertical joint in side jamb where inactive panel and side jamb will meet (FIGURES 1 & 1A).
6. Fill the pocket where sill and side jamb meet with a generous amount of sealant (FIGURE 2). **Do not get caulk into or onto sill or door weep areas (FIGURE 3)!**
7. Install a vinyl bumper on the head jamb for active panel with two #6 x 1-1/2" Phillips flat head 18-8 stainless steel screws (FIGURE 4). Do not overtighten. **Screw head should be flush; not set below surface!**

Continued on next page.

FIGURE 4

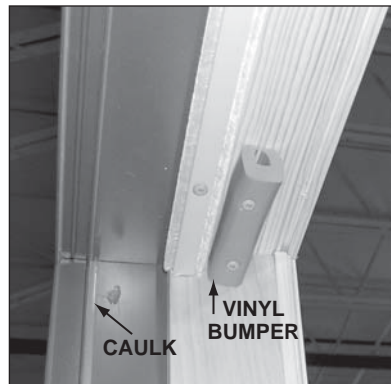

4-Wide – Inactive Insert Installation (cont.)

- Fill entire groove in bottom of inactive insert with silicone sealant. Bead must run entire width of panel and slightly overfill the groove (**FIGURES 5 & 6**).

FIGURE 5

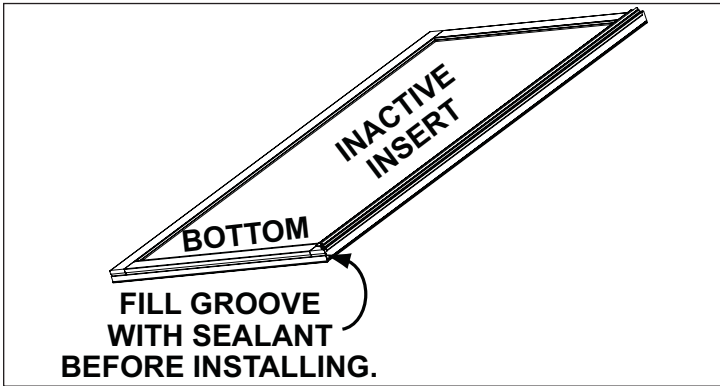
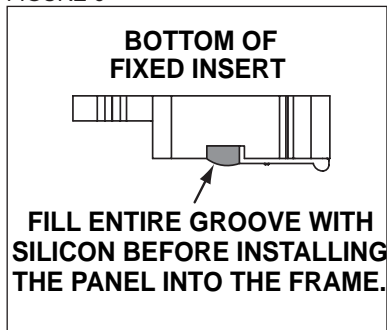

FIGURE 6



4-Wide – Inactive Insert Installation (cont.)

FIGURE 5

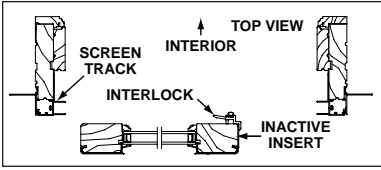

FIGURE 6

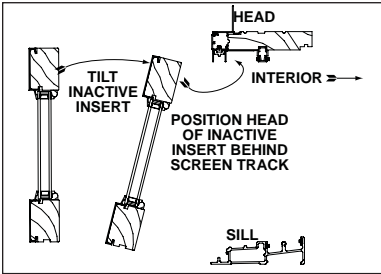

FIGURE 7

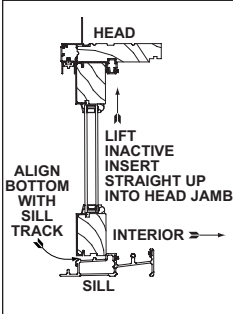
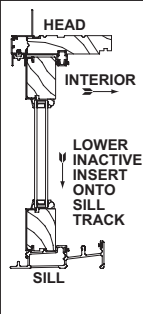

FIGURE 8



⚠ WARNING

Improper use of hand and power tools could result in personal injury and/or product damage. Follow equipment manufacturers' instructions for safe operation. Always wear safety glasses.

⚠ WARNING

Weight of door unit(s) and accessories will vary. Use a reasonable number of people with sufficient strength to lift, carry and install door unit(s) and accessories. Always consider site conditions and use appropriate techniques when installing.

8. While standing facing the exterior side of the supported frame, hold inactive insert vertically with interlock toward center of opening and pointing toward the interior (FIGURE 5). Position insert close to side jamb while leaving enough room for hands and fingers between side jamb and side of inactive insert.

9. Still working from the exterior, tilt head of inactive insert inward (FIGURE 6). Lift insert and position its head behind the screen track.

10. While holding head in this position, swing bottom of inactive insert inward and line up with sill track (FIGURE 7).

11. Lower inactive insert onto sill track and slide tightly to side jamb (FIGURES 7, 8 & 9).

FIGURE 9



4-Wide – Inactive Insert Installation (cont.)

FIGURE 10



! WARNING

Improper use of hand and power tools could result in personal injury and/or product damage. Follow equipment manufacturers' instructions for safe operation. Always wear safety glasses.

! WARNING

Weight of door unit(s) and accessories will vary. Use a reasonable number of people with sufficient strength to lift, carry and install door unit(s) and accessories. Always consider site conditions and use appropriate techniques when installing.

FIGURE 11

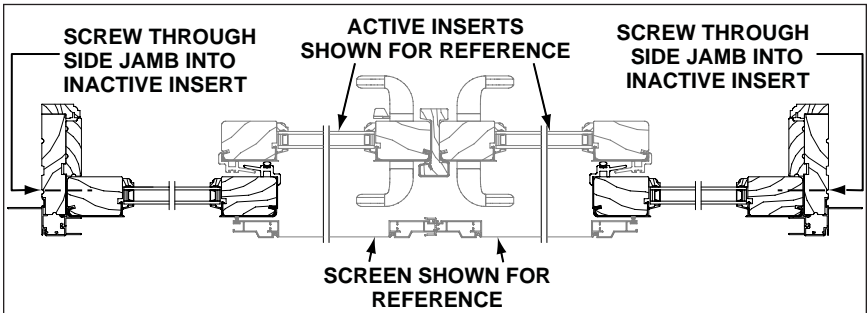

12. Insert a $\frac{3}{4}$ "W x $\frac{5}{32}$ "T x L (length is inactive panel width minus 1- $\frac{3}{4}$ ") wood shim into space between top of inactive insert and head jamb (FIGURE 10).

NOTE: Wood shim **must** be inserted. It prevents head jamb from being distorted when jamb is screwed to top of inactive insert.

13. While holding insert firmly in place against side jamb, use #8 x 2" Phillips flat head 401 stainless steel screws through side jamb into inactive insert to secure side jamb to inactive insert (FIGURE 11). Start screws 8" down from top corner of side jamb and apply a screw every 12" to 16" on center along height of side jamb.

14. In a similar manner, using #8 x 2" Phillips flat head 401 stainless steel screws, secure head jamb to inactive insert by screwing through head jamb down into inactive insert. Start screws 6" from corner of side jamb and apply a screw every 12" to 16" on center along width of inactive insert (FIGURE 12).

FIGURE 12

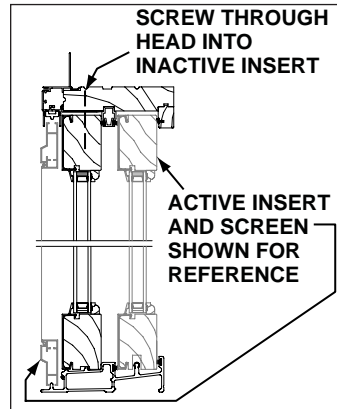

4-Wide – Inactive Insert Installation (cont.)

FIGURE 13



15. Seal gap between inactive insert and head jamb with self-stick Q-LON corner seal. Trim pad to fit, peel release liner and stick pad in place (FIGURES 13 & 14).

16. Clean up any excess caulk using a spray bottle filled with denatured alcohol and a soft clean shop towel.

17. Repeat Steps 5 through 16 to install second inactive insert.

FIGURE 14



WARNING

Improper use of hand and power tools could result in personal injury and/or product damage. Follow equipment manufacturers' instructions for safe operation. Always wear safety glasses.

4-Wide – Inactive Insert Installation (cont.)

FIGURE 1



FIGURE 2

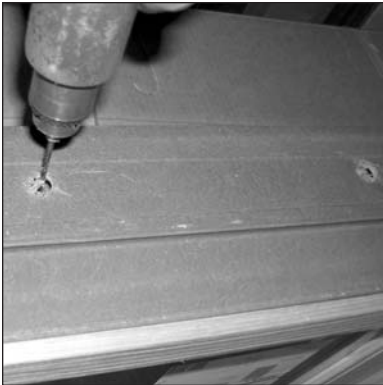
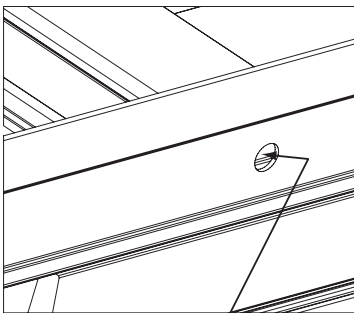

FIGURE 3



PLACE A 1/8" BEAD OF SILICONE OVER THE 1/8" PILOT HOLE TO SEAL THE SCREW TO THE FIBERGLASS SILL.



WARNING

Weight of door unit(s) and accessories will vary. Use a reasonable number of people with sufficient strength to lift, carry and install door unit(s) and accessories. Always consider site conditions and use appropriate techniques when installing.

Secure Inactive Inserts Through Bottom of Sill

1. Very carefully lay frame, with inactive inserts installed, down to gain access to underside of sill.

NOTE: If 9/16" diameter holes are not present in bottom of sill, perform Step 2 followed by Steps 3 and 4. If holes are present, start with Step 3; then perform Step 4.

2. In area below inactive insert drill a set of 9/16" diameter holes through sill's outer wall **ONLY** (FIGURE 1). Locate first hole 1-1/2" from edge of stile. Locate second hole 6" to 8" from first hole (FIGURE 1).

NOTE: Panels over 30" wide should be drilled for three screws following above spacing guidelines.

3. Drill 1/8" pilot holes through center of each 9/16" hole. These smaller holes should penetrate sill and extend up into inactive inserts (FIGURE 2).

4. Apply a 1/8" bead of silicone sealant into and over each pilot hole to seal the screw to the fiberglass sill (FIGURE 3).

5. Secure sill to inactive insert with a #10 x 1-1/2" Phillips pan head stainless steel screw applied through each 9/16" hole (FIGURES 4 & 5). Tighten screws until heads are flush with the sill.

FIGURE 4



4-Wide – Inactive Insert Installation (cont.)

FIGURE 5

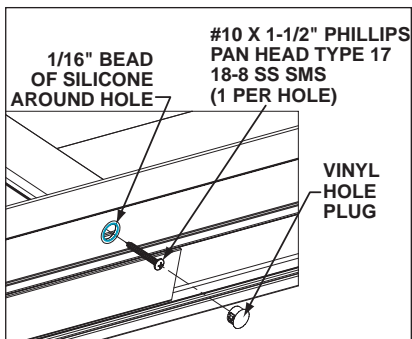
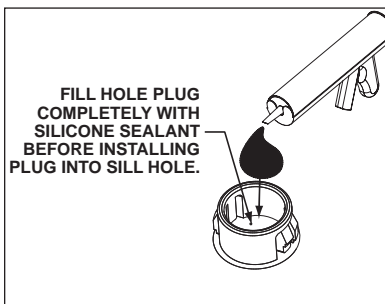

FIGURE 6



FIGURE 7



6. After screws are firmly seated, fill hole with generous amount of silicone sealant (FIGURE 6).

7. Apply a 1/16" silicone bead around the 9/16" diameter hole (FIGURE 5).

8. Completely fill the hole plug with silicone sealant (FIGURE 7).

9. After silicone sealant is applied to all locations described above, insert screw plugs into each hole (FIGURE 8).

Make sure plug's head is fully seated onto the sill. There should be silicone squeeze out all the way around the hole plug.

10. Repeat Steps 2 through 9 for each inactive insert.

After inactive inserts are secured in the frame the frame/insert assembly can be installed in the rough opening.

CAUTION Use care when transporting assembled unit to rough opening. Use adequate number of people, do not flex frame, do not damage alignment of components.

Follow [Installation Instructions](#) starting on Page 6 for clad nailing fin units or Page 11 for wood brickmould units.

- See Page 17 for screen installation.
- See Page 19 for active insert installation.

FIGURE 8

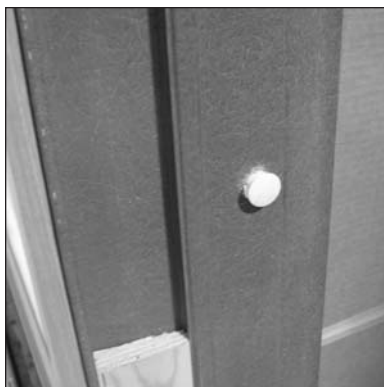

Products With Synthetic Stucco

Serious concerns have been raised about excessive moisture problems in homes and other buildings that have Exterior Insulation Finish Systems, commonly referred to as EIFS or Synthetic Stucco.

Many experts agree that a certain amount of water or moisture can be expected to enter almost any building exterior system. The building system should allow such water and moisture to escape or “weep” to the exterior, so no damage occurs. However, some EIFS systems may not allow water or moisture that penetrates the wall system to “weep” to the exterior. This can cause excessive moisture to accumulate within the wall system, which can cause serious damage to wall and other building components. It has been reported that so-called “barrier” EIFS systems are particularly prone to this problem.

Moisture problems in any type of building structure can be reduced by proper design and construction with appropriate moisture control considerations, taking into account prevailing climate conditions. Examples of moisture control considerations include flashing and/or sealing of all building exterior penetration points, use of appropriate materials and construction techniques, adherence to applicable building codes, and general attention to proper design and workmanship of the entire building system, including allowances for management of moisture within the wall system.

Determination of proper building design, components and construction, including moisture management, are the responsibility of the design architect, the contractors, and the manufacturer of the exterior wall finish products. Questions and concerns about moisture management issues should be taken up with these professionals. The door manufacturer is not responsible for problems or damages caused by deficiencies in building design, construction or maintenance, failure to install our products properly, or use of our products in systems that do not allow for proper management of moisture within the wall system.



Install 106J Rev. 2 03/07 P/N 207305
Install 111J Rev. 3 03/07 P/N 207304
TPC 599816 Rev. 2 03/07

WS-1172749 Rev. 2 03/07

Printed in U.S.A.

©2007 Door Manufacturer
